

AKAI SERVICE MANUAL

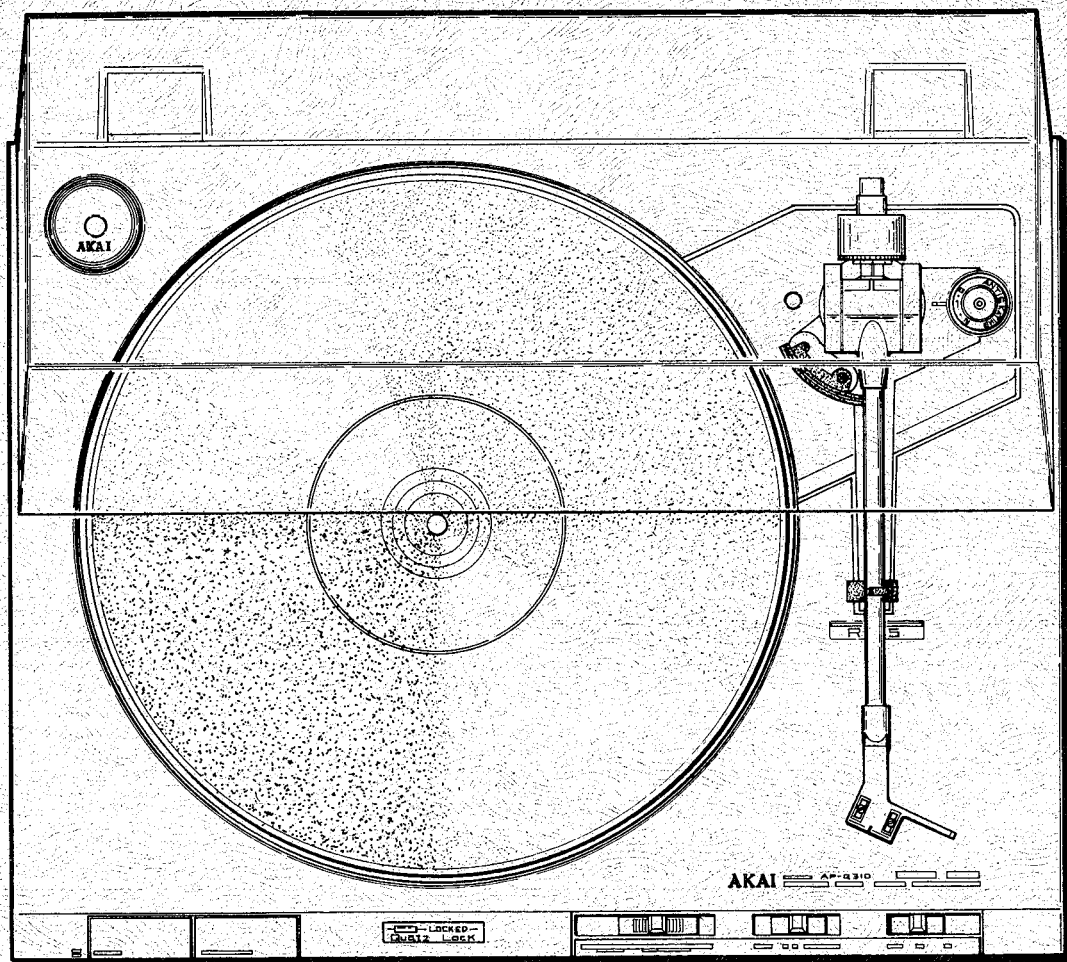

QUARTZ FULL AUTO TURNTABLE

AP-Q310/C

AP-Q310/C



QUARTZ FULL AUTO TURNTABLE
MODEL AP-Q310/C

This manual is applicable to both silver and pearl shadow panel models.

TABLE OF CONTENTS

SECTION 1	SERVICE MANUAL.....	3
SECTION 2	PARTS LIST.....	25
SECTION 3	SCHEMATIC DIAGRAM.....	32

SAFETY INSTRUCTIONS

SAFETY CHECK AFTER SERVICING

Confirm the specified insulation resistance between power cord plug prongs and externally exposed parts of the set is greater than 10 Mohms, but for equipment with external antenna terminals (tuner, receiver, etc.) and is intended for **C** or **A**, specified insulation resistance should be more than 2.2 Mohms (ground terminals, microphone jacks, headphone jacks, line-in-out jacks etc.)

PRECAUTIONS DURING SERVICING

1. Parts identified by the Δ symbol parts are critical for safety.
Replace only with parts number specified.
2. In addition to safety, other parts and assemblies are specified for conformance with such regulations as those applying to spurious radiation. These must also be replaced only with specified replacements.
Examples: RF converters, tuner units, antenna selector switches, RF cables, noise blocking capacitors, noise blocking filters, etc.
3. Use specified internal wiring. Note especially:
 - 1) Wires covered with PVC tubing
 - 2) Double insulated wires
 - 3) High voltage leads
4. Use specified insulating materials for hazardous live parts. Note especially:
 - 1) Insulation Tape
 - 2) PVC tubing
 - 3) Spacers (Insulating Barriers)
 - 4) Insulation sheets for transistors
5. When replacing AC primary side components (transformers, power cords, noise blocking capacitors, etc.), wrap ends of wires securely about the terminals before soldering.

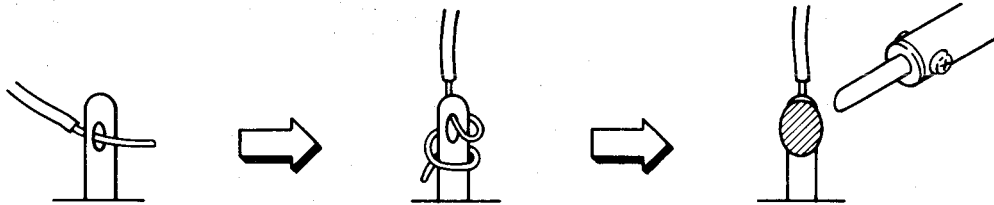

6. Observe that wires do not contact heat producing parts (heatsinks, oxide metal film resistors, fusible resistors, etc.).
7. Check that replaced wires do not contact sharp edged or pointed parts.
8. Also check areas surrounding repaired locations.
9. Use care that foreign objects (screws, solder droplets, etc.) do not remain inside the set.

SECTION I

SERVICE MANUAL

TABLE OF CONTENTS

I.	SPECIFICATIONS	4
II.	DISMANTLING OF UNIT	5
III.	CONTROLS	6
IV.	PRINCIPAL PARTS LOCATION.....	7
V.	VOLTAGE AND CYCLE CONVERSION	8
	1. VOLTAGE CONVERSION.....	8
	2. CYCLE CONVERSION.....	8
VI.	ORDINARY ADJUSTMENT.....	9
	1. STYLUS PRESSURE ADJUSTMENT	9
	2. OVERHANG (Not necessary for AP-Q310/C).....	10
VII.	MECHANICAL ADJUSTMENT.....	11
	1. TONE ARM LIFTER ADJUSTMENT	11
	2. TONE ARM BRAKE ADJUSTMENT	12
	3. LEAD-IN/LEAD-OUT ADJUSTMENT.....	13
	4. RETURN PLUNGER POSITION ADJUSTMENT.....	13
VIII.	ELECTRICAL ADJUSTMENT.....	14
	1. OFF-SET VOLTAGE ADJUSTMENT (VR2, 3) AND TORQUE DIFFERENCE ADJUSTMENT (VR1).....	14
	2. WOW AND FLUTTER CONFIRMATION.....	14
IX.	CLASSIFICATION OF VARIOUS P.C BOARDS	15
	1. P.C BOARD TITLES AND IDENTIFICATION NUMBERS.....	15
	2. COMPOSITION OF VARIOUS P.C BOARDS	16

For basic adjustments, measuring methods, and operating principles, refer to
GENERAL TECHNICAL MANUAL.

I. SPECIFICATIONS

TURNTABLE	Aluminum alloy die cast
DRIVE SYSTEM & MECHANISM	Quartz Locked Direct Drive, Fully Automatic
MOTOR	DC servo motor
SPEED	33-1/3 rpm, 45 rpm
SPEED DEVIATION	±0.002%
WOW & FLUTTER	0.045% (DIN), 0.03% (JIS)
RUMBLE	48 dB (DIN A), 73 dB (DIN B)
TONE ARM	Static Balanced Type
EFFECTIVE ARM LENGTH	220 mm
STYLUS PRESSURE ADJUSTMENT RANGE	0 to 2.5 grams
APPLICABLE CARTRIDGE WEIGHT	3 to 8 grams
ARM LIFTER	Oil damped
OVERHANG	17.5 mm
OFFSET ANGLE	24°
HORIZONTAL TRACKING ERROR ANGLE	+2°40' (Outside) -1° (Inside)
CARTRIDGE	VM (Dual Magnet) type (Model AP-Q310 does not include cartridge.)
OPTIMAL STYLUS PRESSURE	2 grams
OUTPUT VOLTAGE	5 mV (DIN)
CHANNEL SEPARATION	20 dB
FREQUENCY RESPONSE	20 to 20,000 Hz
CARTRIDGE LOAD IMPEDANCE	47 kohms
STATIC VERTICAL COMPLIANCE	16×10^{-6} cm/dyne
STATIC HORIZONTAL COMPLIANCE	12.5×10^{-6} cm/dyne
DYNAMIC VERTICAL COMPLIANCE	4.5×10^{-6} cm/dyne
DYNAMIC HORIZONTAL COMPLIANCE	4.5×10^{-6} cm/dyne
POWER REQUIREMENTS	100V, 50/60 Hz for Japan 120V, 60 Hz for USA and Canada 220V, 50Hz for Europe except UK 240V, 50 Hz for UK and Australia 110-120V/220-240V, 50/60 Hz switchable for other countries
POWER CONSUMPTION	6W
DIMENSIONS	440 (W) × 98 (H) × 359 (D) mm (17.3 × 3.9 × 14.1 inches)
WEIGHT	5.4 kg (11.9 lbs)

* For improvement purposes, specifications and design are subject to change without notice.

II. DISMANTLING OF UNIT

In case of trouble, etc. necessitating dismantling, please dismantle in the order shown in the photographs. Reassemble in reverse order.

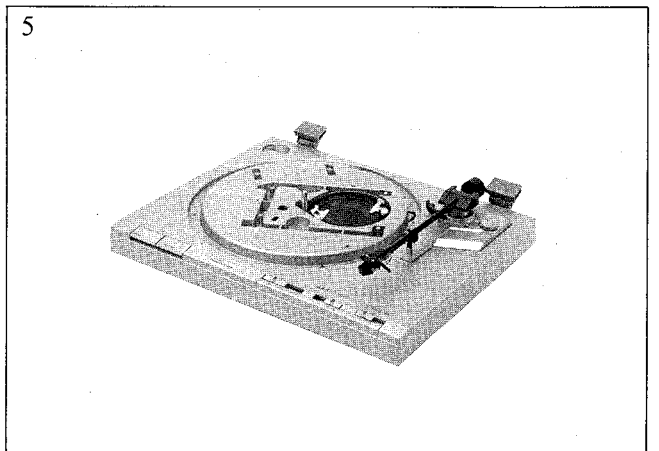
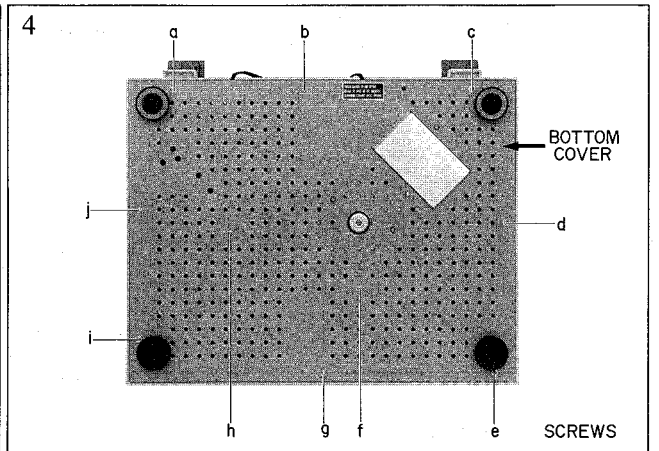
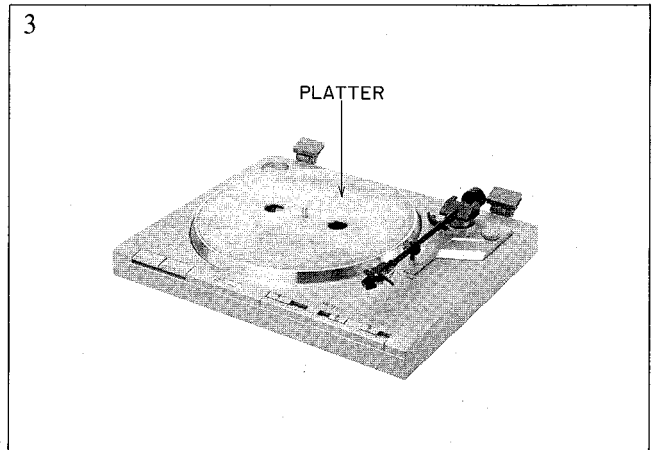
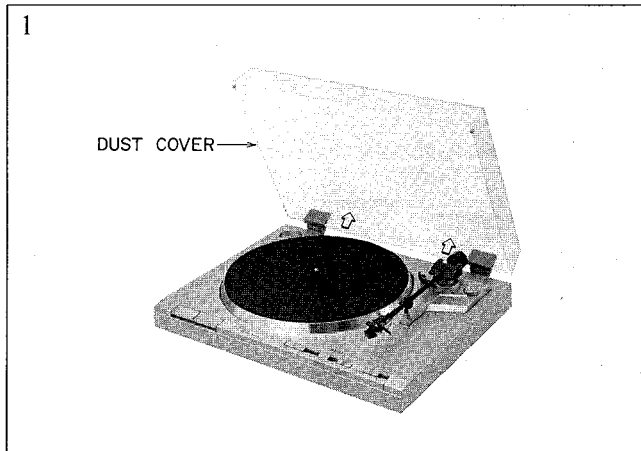

III. CONTROLS

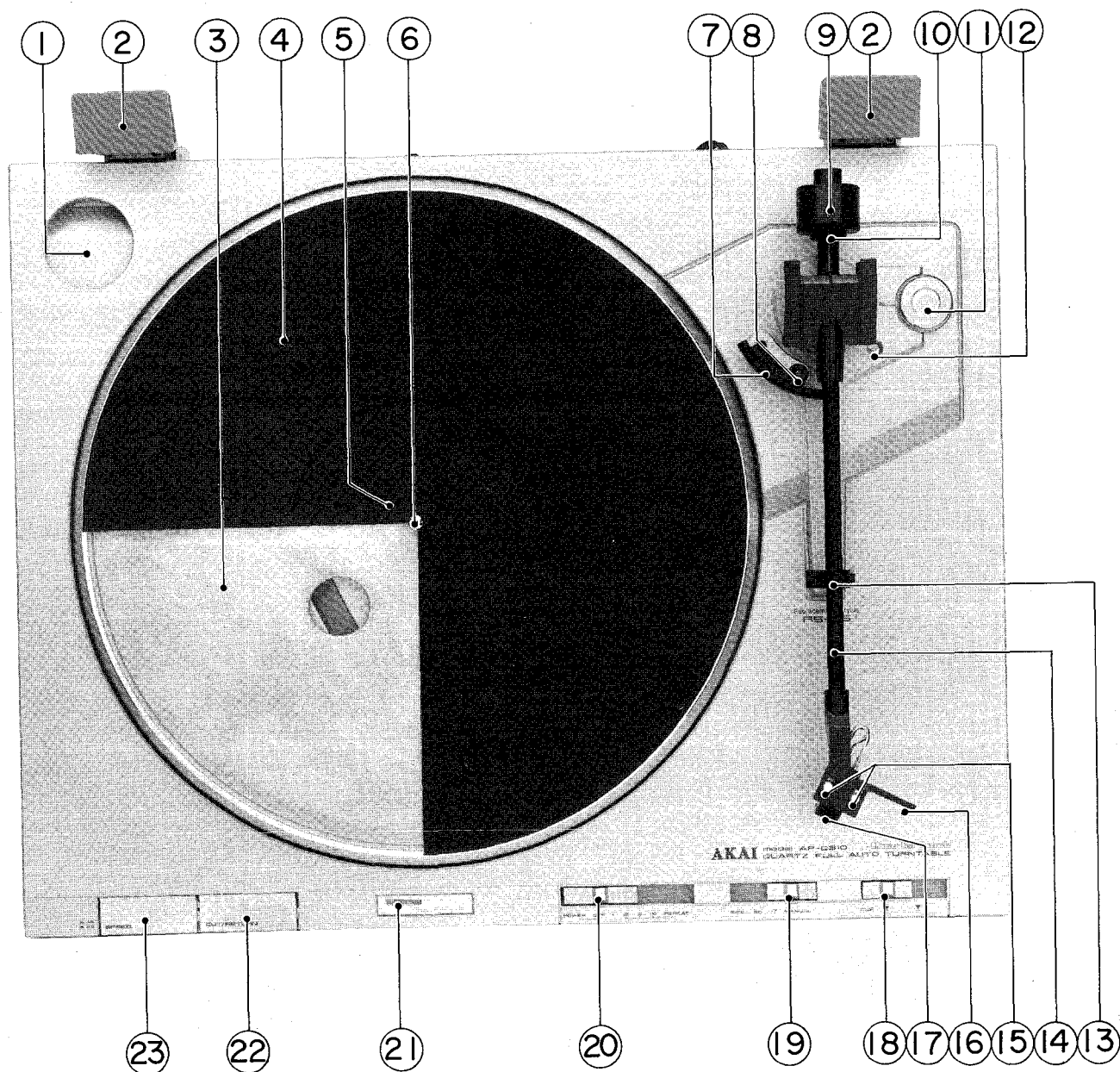

Fig. 1 Controls

- | | |
|--|---|
| 1. 45 rpm ADAPTER HOLDER | 13. TONE ARM REST AND CLAMP |
| 2. HINGE | 14. TONE ARM |
| 3. PLATTER | 15. CARTRIDGE RE-SETTING SCREWS |
| 4. RUBBER MAT | 16. HEAD SHELL |
| 5. GROOVE FOR OVERHANG ADJUSTMENT | 17. CARTRIDGE (AP-Q310/C ONLY) |
| 6. SPINDLE | 18. CUEING (CUE) LEVER (▼ TO LIFT, ▼ TO LOWER) |
| 7. TONE ARM LIFTER | 19. SIZE/MANUAL MODE SELECTOR |
| 8. TONE ARM LIFTER HEIGHT ADJUSTMENT SCREW | 20. POWER/REPEAT SELECTOR |
| 9. MAIN WEIGHT | 21. QUARTZ LOCK INDICATOR |
| 10. STYLUS PRESSURE SCALE RING | 22. CUT/RETURN SWITCH |
| 11. ANTISKATING ADJUSTMENT | 23. SPEED SELECTOR |
| 12. LEAD-IN/LEAD-OUT ADJUSTMENT SCREW | |

IV. PRINCIPAL PARTS LOCATION

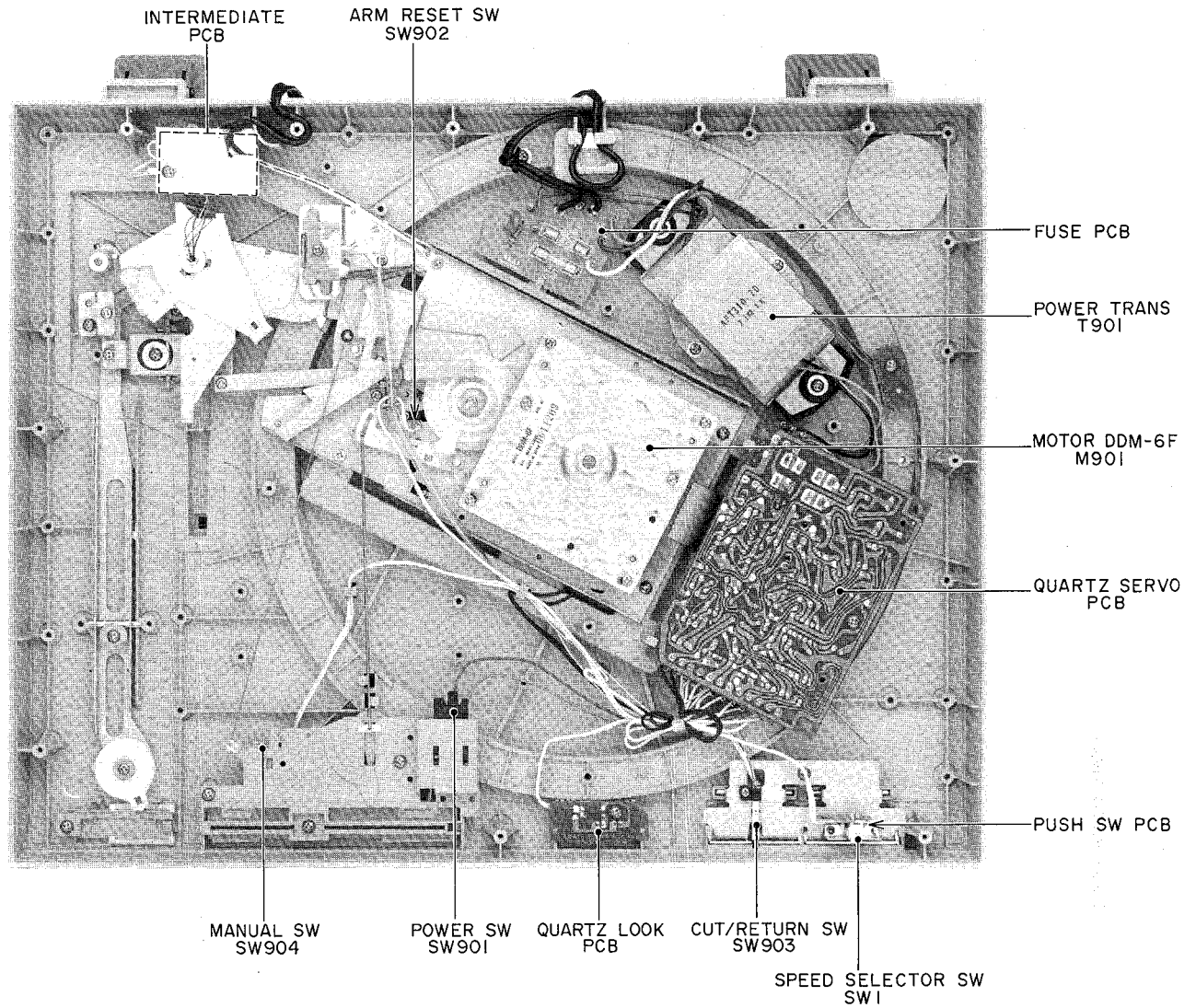
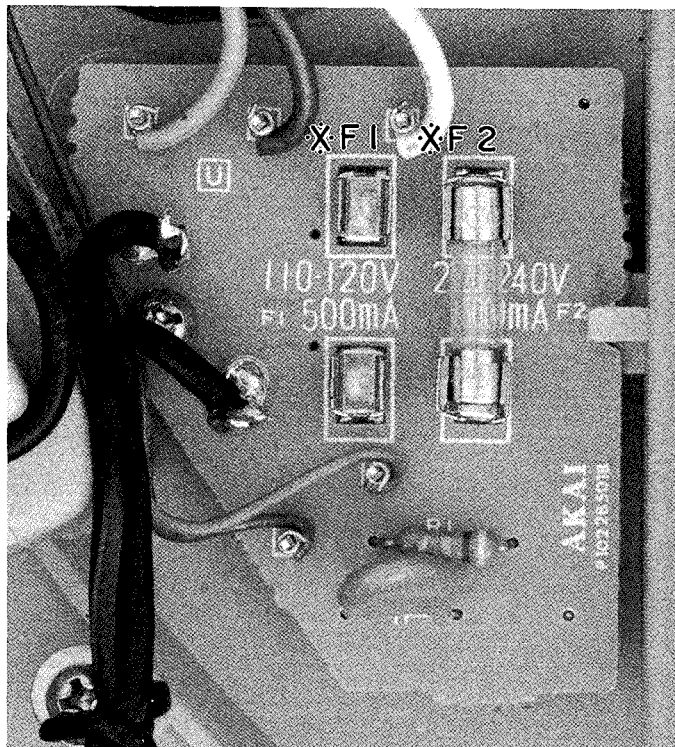

Fig. 2 Principal Parts Location (Bottom View)

V. VOLTAGE AND CYCLE CONVERSION



※	F 1	F 2
110,120V AREA	500mA 250V	OPEN
220,240V AREA	OPEN	500mA 250V

Fig. 3 Voltage Conversion (U Model only)

1. VOLTAGE CONVERSION

Models for Japan, Canada, USA, Europe, UK and Australia are not equipped with this facility.

Each unit is preset at the factory depending on its destination, but some units can be converted to 110-120V or to 220-240V as required.

If voltage change is necessary, this can be accomplished as follows:

- 1) Disconnect the power cord.
- 2) Remove the bottom cover.
- 3) Remove the existing Line Voltage Fuse and insert the required Line Voltage Fuse in the proper fuse holder according to the printed instructions.

2. CYCLE CONVERSION

With DC servo motor, cycle conversion is not necessary.

VI. ORDINARY ADJUSTMENT

1. STYLUS PRESSURE ADJUSTMENT (Refer to Fig. 4)

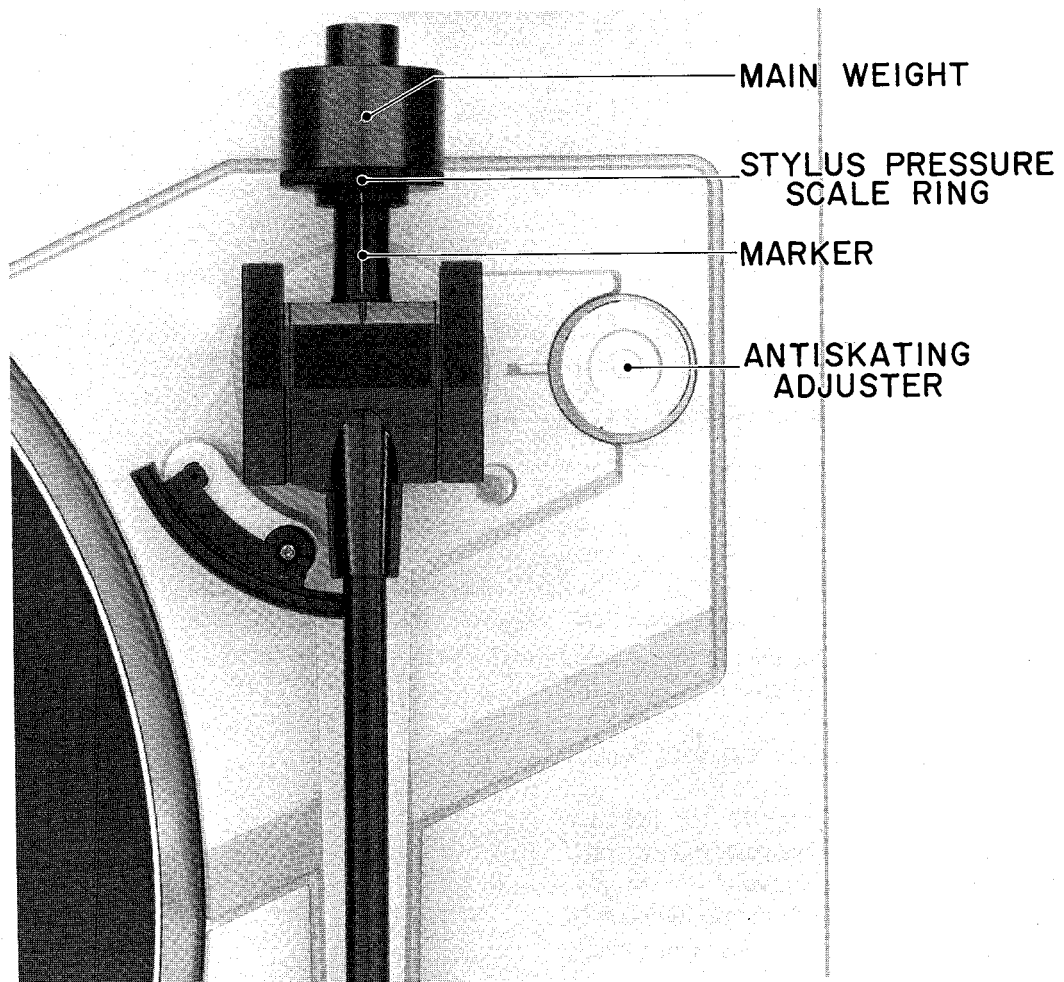
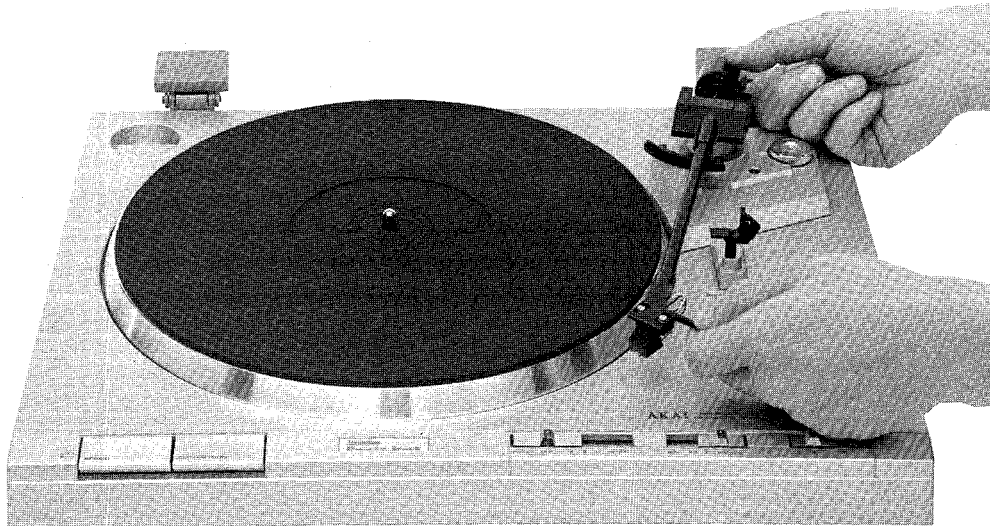

Fig. 4 Stylus Pressure Adjustment

- 1) Connect the Power Cord.
- 2) Set the ANTISKATING adjuster to "0".
- 3) Set the CUE lever to ▼.
- 4) Set the SIZE/MANUAL Mode selector to MANUAL.
- 5) Unlock the Tone Arm and bring it towards the Platter.
 - * Remove the Stylus Guard being careful not to damage the Stylus.
- 6) Set the POWER/REPEAT selector to "1".
The Tone Arm Lifter will be lowered.
- 7) With the Tone Arm held midway between the Tone Arm Rest and the rim of the Platter, adjust the Main Weight until the Tone Arm is in perfect horizontal balance.
- 8) Without moving the Main Weight, rotate the Stylus Pressure Scale Ring only to match the "0" mark with the mark on the weight shaft.
- 9) Depress the CUT/RETURN switch.
- 10) Lock the Tone Arm in place and rotate the Main Weight counterclockwise, as viewed from the front (the Stylus Pressure Scale Ring will move with it), until the desired Stylus Pressure Scale indication is at the mark on the shaft. The range of adjustment is from 0 to 2.5 grams.
 - * For AP-Q310/C only: The recommended stylus pressure for the cartridge supplied, PC-85, is 2 grams.
- 11) Set the ANTISKATING adjuster to the corresponding stylus pressure.

2. OVERHANG (Not necessary for AP-Q310/C) (Refer to Fig. 5)

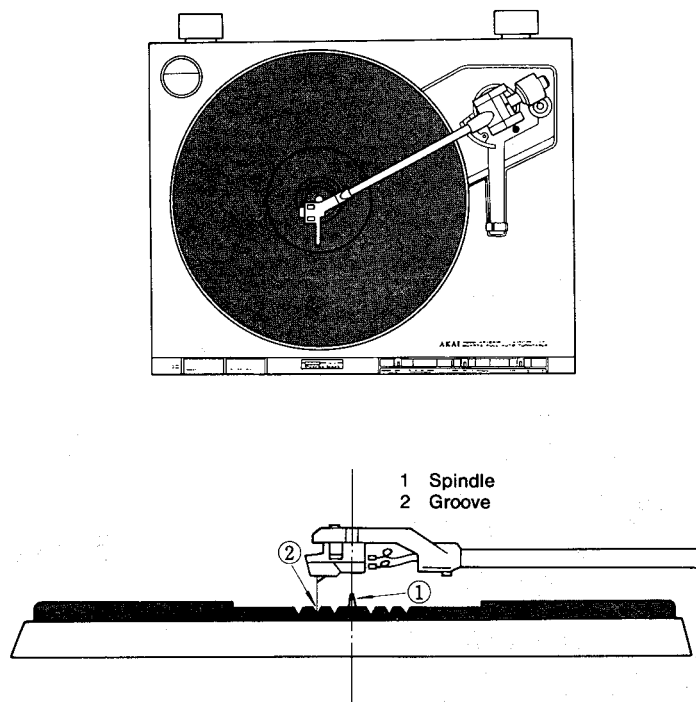

Fig. 5 Overhang Adjustment

The Distance between the Spindle and the Stylus when the Tone Arm is centered over the Platter is known as the Overhang.

Different cartridges require different Overhang Adjustments.

For your convenience, the Rubber Mat has indicator grooves at the center to facilitate Overhang Adjustment.

- 1) Center the Tone Arm over the Platter.
- 2) Adjust the Cartridge so that the Stylus position is even with the Groove for Overhang Adjustment (middle groove ring).

* The Cartridge position can be adjusted by resetting the Cartridge Re-Setting Screws in the Head Shell.

VII. MECHANICAL ADJUSTMENT

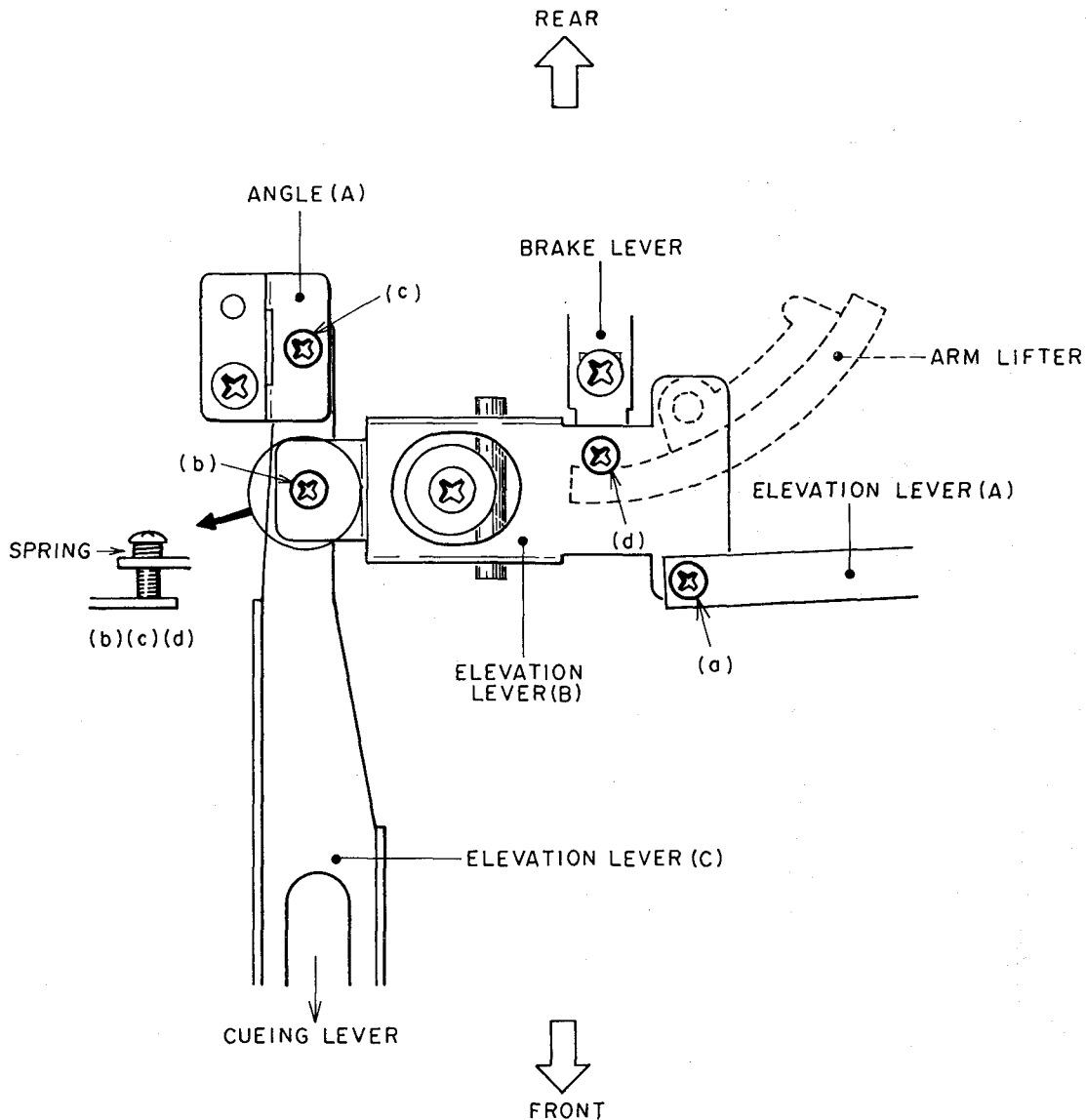

Fig. 6 Tone Arm Lifter Adjustment and Tone Arm Brake Adjustment

1. TONE ARM LIFTER ADJUSTMENT

(Refer to Fig. 6)

- 1) The height of the stylus point is adjusted when the arm is lifted in AUTO PLAY and manually (cueing lever).
 - a) Adjust the size selector to 17 cm.
 - b) Remove the rubber mat and platter and turn the main gear $3/4$ counterclockwise. (Lead in → arm down → arm up → when returning)
 - c) Loosen the screws (b) and (c).
 - d) Check that the screw (a) is fully clockwise.
 - e) Set the cueing lever to ▼ (UP).
 - f) Tighten the screw (b) slowly so that the stylus point will be about 1 – 2 mm higher than when the stylus is lifted in AUTO PLAY. (Check by moving the cueing lever ▼ (UP) ... ▼ (DOWN).
 - g) Tighten the screw (c) until the end almost touches the elevation lever (c). (Cueing lever: ▼)
 - h) While repeating the operation of ▼ (UP) ↔ ▼ (DOWN) of the cueing, tighten the screw (c) until the stylus point hardly changes.
 - i) Have the auto return finished by turning the main gear $1/4$.
 - j) Paintlock the screws (a), (b) and (c).

2) Tone Arm Lifter Height Adjustment (Refer to Fig. 7).

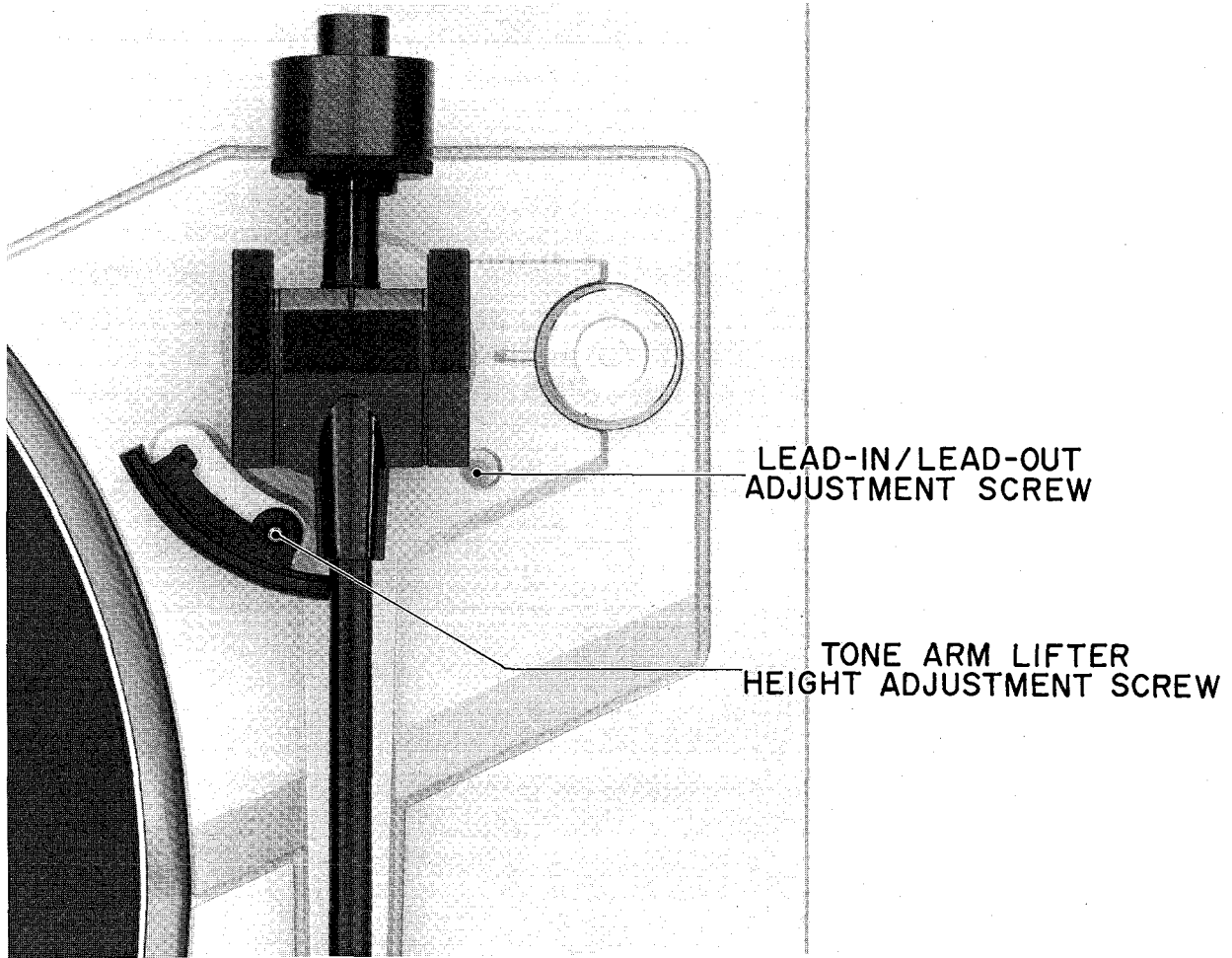

Fig. 7 Tone Arm Lifter height Adjustment and Lead-IN/Lead-OUT Adjustment

With the Tone Arm in the up position, the Stylus should be 5 to 7 mm above the surface of the record. If it is not, adjust the height by adjusting the Tone Arm Lifter Height Adjustment Screw.

- Clockwise: down
- Counterclockwise: up

2. TONE ARM BRAKE ADJUSTMENT

(Refer to Fig. 6)

The arm brake the horizontal movement of the arm to have it move smoothly when AUTO LEAD-IN and AUTO RETURN. AP-Q310 uses the friction of the felt.

- 1) Carry out 1-1) a) and b).
- 2) Provide the horizontal balance of the tone arm. (It means that the tone arm is away from the arm lifter).
- 3) Adjust the antiskating adjuster to 2.
- 4) When the screw (d) is loosened, the tone arm starts to move toward the periphery (the situation where the

brake will not be functioning).

- 5) Have the tone arm move near to the outer periphery of a 17 cm record, and tighten the screw (d) slowly to the point where it does not move toward the outer periphery any more even the hand is removed (point where the brake starts to function).
- 6) From the status of 5), tighten the screw (d) one more turn clockwise.
- 7) Paintlock the screw (d).

3. LEAD-IN/LEAD-OUT ADJUSTMENTS

(Refer to Fig. 7)

1) Lead-in position

- a) Place a record on the Platter.
- b) Auto-play the record and confirm where the Stylus descends.
- c) Depress the CUT/RETURN switch to return the Tone Arm to the Tone Arm Rest.
- d) Move the Tone Arm towards the Platter until the Lead-in Adjustment Screw is visible.
- e) Turn the Lead-in Adjustment Screw with a screw-driver:

Clockwise: To make the Stylus descend towards the Spindle.

Counterclockwise: To make the Stylus descend away from the Spindle.

2) Lead-out position

- a) Auto-play the record and confirm where auto-return begins.
- b) Turn the Lead-out Adjustment Screw with a screw-driver:

* The Lead-out Adjustment Screw is visible without moving the Tone Arm.

Clockwise: To delay auto-return.

Counterclockwise: To hasten auto-return.

NOTE: Carry out both adjustments little at a time and confirm the position after each adjustment.

4. RETURN PLUNGER POSITION ADJUSTMENT (Refer to Fig. 8)

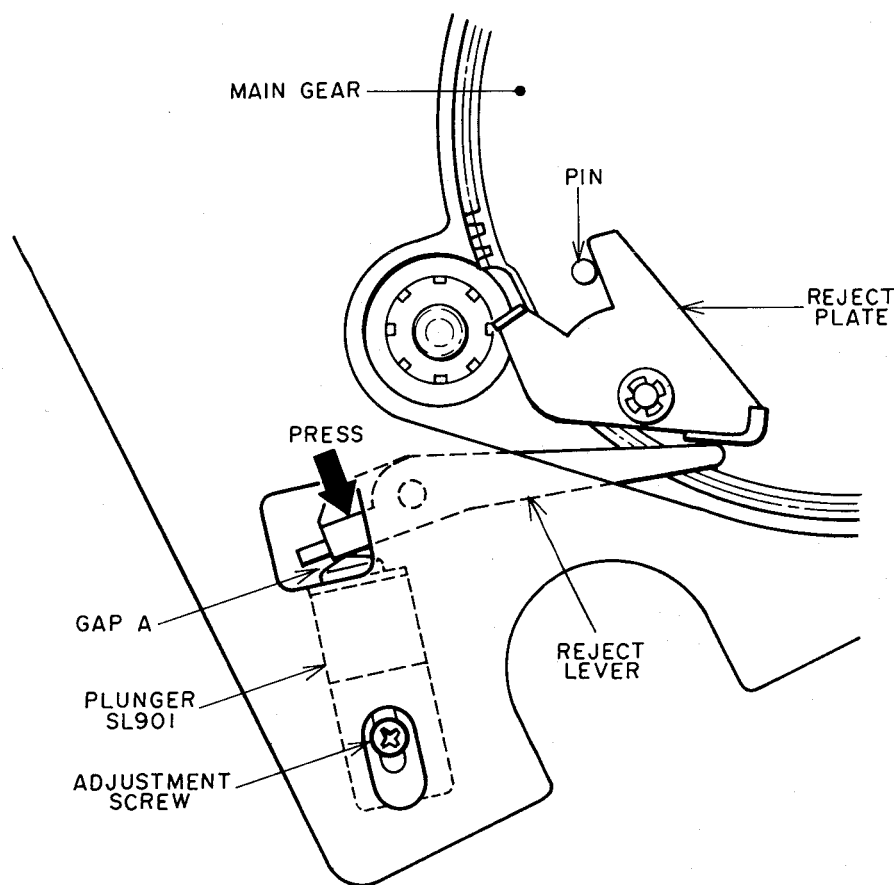

Fig. 8 Return Plunger Position Adjustment

Press the reject lever down with a finger until the reject plate touches the main gear pin. Operate the plunger (SL901) in this position and adjust the installation screw at exactly the point where the gap A between the reject lever and plunger disappears. (Refer to Fig. 8)

After adjustment, confirm that the Auto Play is operating.

VIII. ELECTRICAL ADJUSTMENT

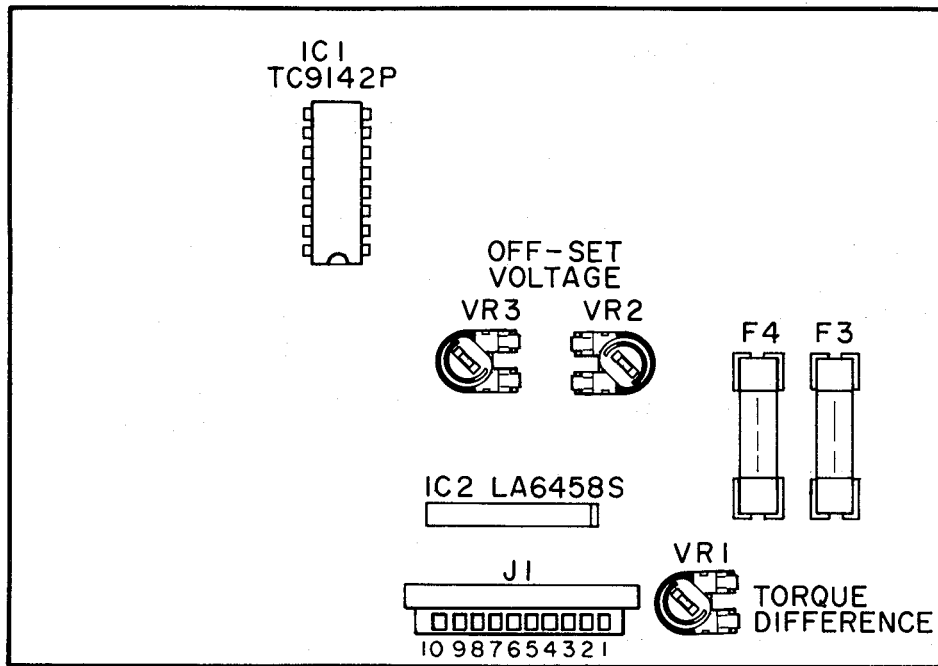

Fig. 9 Quartz Servo PCB (Parts side View)

1. OFF-SET VOLTAGE ADJUSTMENT (VR2, 3) AND TORQUE DIFFERENCE ADJUSTMENT (VR1)

- 1) Disconnect the motor connection cord (J1).
- 2) Short connector (J1) pins (7), (8) and (1).
- 3) Set VR1 to the center.
- 4) Turn the power switch ON.
- 5) Connect a digital voltmeter to terminal (10) of connector J1 and adjust VR3 until it reads -120 mVDC.
- 6) Turn the power switch OFF.
- 7) Short connector (J1) pins (4), (5) and (1).
- 8) Turn the power switch ON.
- 9) Connect a digital voltmeter to terminal (9) of connector J1 and adjust VR2 until it reads -120 mVDC.
- 10) Turn the power switch OFF and connect the motor connection wire to connector (J1).
- 11) Connect an oscilloscope to (9) and (10) of connector (J1).
- 12) Turn the power switch ON.
- 13) Set the SIZE/MANUAL selector to MANUAL.
- 14) Turn the power switch ON to rotate platter.
- 15) Adjust VR1 so that the voltage of connector (J1)'s (9) and (10) may be the same. (The voltage indicated in (9) and (10) is for switching motor coil, and its frequency is very low.

2. WOW AND FLUTTER CONFIRMATION

- 1) Playback the test record (3,000 Hz).
- 2) Confirm that the Wow and Flutter is within 0.03% (JIS).
- 3) If not, re-adjust VR1, VR2 and VR3.

IX. CLASSIFICATION OF VARIOUS P.C BOARDS

1. P.C BOARD TITLES AND IDENTIFICATION NUMBERS

P.C BOARD TITLE	P.C BOARD NUMBER	* NOTES
Quartz Servo P.C Board	P1022B501A	U
Quartz Servo P.C Board	P1022B502A	C, A
Quartz Servo P.C Board	P1022B503A	E, V, S
Quartz Servo P.C Board	P1022B504A	B
Quartz Servo P.C Board	P1022B505A	J
Fuse P.C Board	P1022B501B	U
Fuse P.C Board	P1022B502B	C, A
Fuse P.C Board	P1022B503B	E, V, S
Fuse P.C Board	P1022B504B	B
Fuse P.C Board	P1022B505B	J
Push P.C Board	P1022B501C	U
Push P.C Board	P1022B502C	C, A
Push P.C Board	P1022B503C	E, V, S
Push P.C Board	P1022B504C	B
Push P.C Board	P1022B505C	J
Quartz Lock P.C Board	P1022B501D	U
Quartz Lock P.C Board	P1022B502D	C, A
Quartz Lock P.C Board	P1022B503D	E, V, S
Quartz Lock P.C Board	P1022B504D	B
Quartz Lock P.C Board	P1022B505D	J
Lead Switch P.C Board	P1022B501E	U
Lead Switch P.C Board	P1022B502E	C, A
Lead Switch P.C Board	P1022B503E	E, V, S
Lead Switch P.C Board	P1022B504E	B
Lead Switch P.C Board	P1022B505E	J
Intermediate P.C Board	P1022B501F	U
Intermediate P.C Board	P1022B502F	C, A
Intermediate P.C Board	P1022B503F	E, V, S
Intermediate P.C Board	P1022B504F	B
Intermediate P.C Board	P1022B505F	J

2. COMPOSITION OF VARIOUS P.C BOARDS

1) Quartz Servo P.C Board P1022B501A (U), P1022B502A (C, A), P1022B503A (E, V, S), P1022B504A (B), P1022B505A (J)

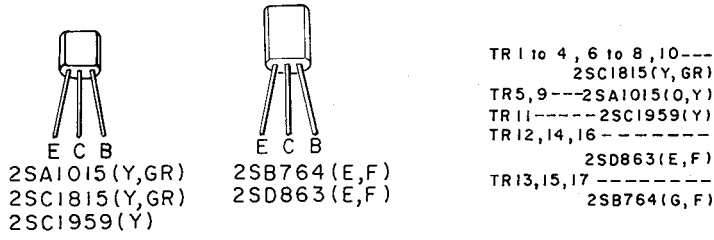

QUARTZ SERVO PCB
 P1022B501A(U)
 P1022B502A(A,C)
 P1022B503A(E,V,S)
 P1022B504A(B)
 P1022B505A(J)

LOCATION OF
IC, TR & CONNECTOR

IC1-2B	TR1-1A
IC2-1B	TR2-1A
	TR3-1B
P1-1C	TR4-2B
P2-1,2A	TR5-2B
	TR6-1B
J1-1B	TR7-2A
	TR8-2A
	TR9-1A
	TR10-1A
	TR11-1A
	TR12-1C
	TR13-1B
	TR14-1B
	TR15-1B
	TR16-2B
	TR17-2C

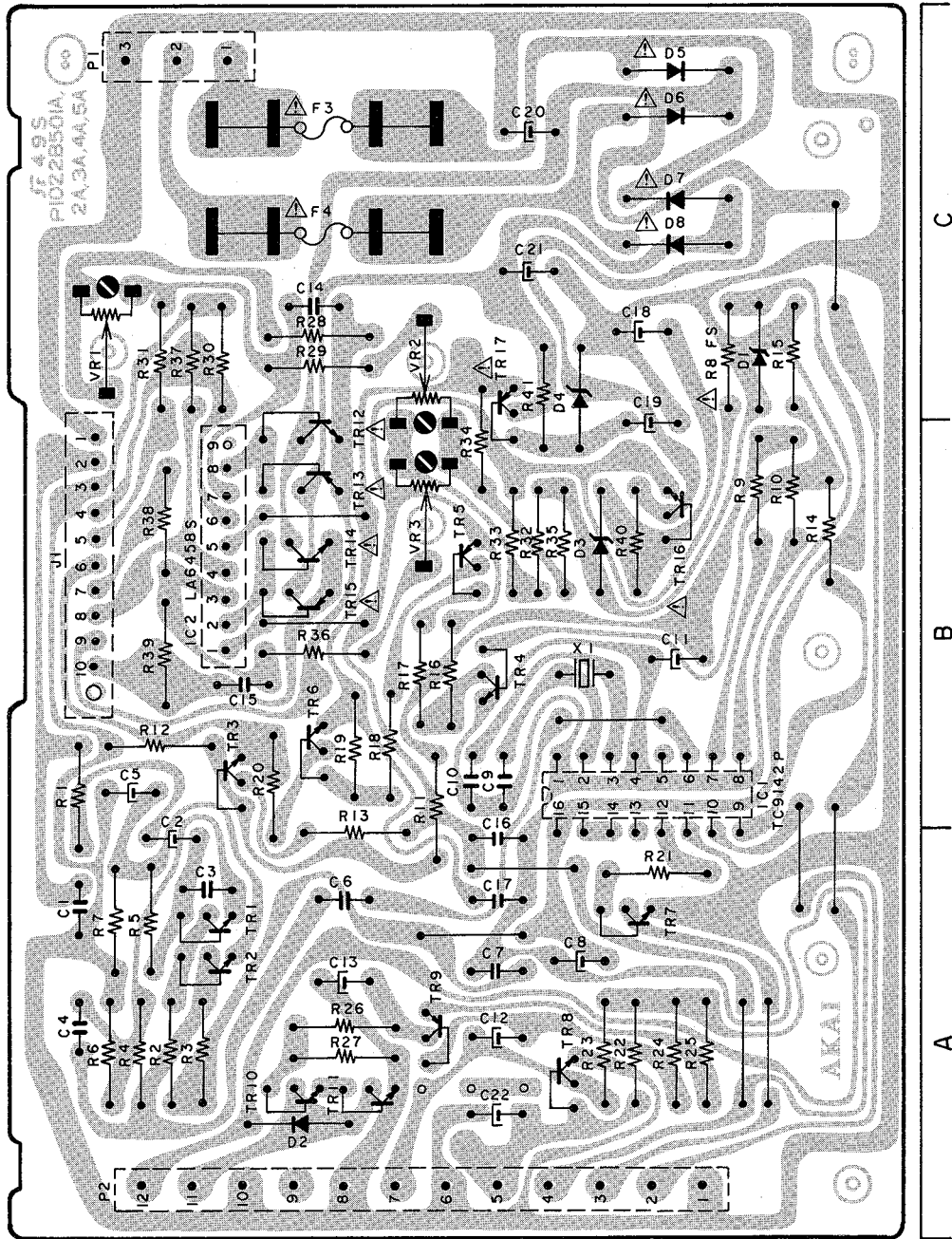

WARNING: Δ INDICATES SAFETY CRITICAL COMPONENTS. FOR CONTINUED SAFETY,
 REPLACE SAFETY CRITICAL COMPONENTS ONLY WITH MANUFACTURER'S
 RECOMMENDED PARTS
 AVERTISSEMENT: Δ IL INDIQUE LES COMPOSANTS CRITIQUES DE SÛRETÉ. POUR
 MAINTENIR LE DEGRÉ DE SÛRETÉ DE L'APPAREIL, NE REMPLACER LES
 COMPOSANTS DONT LE FONCTIONNEMENT EST CRITIQUE POUR LA SÛRETÉ
 QUE PAR DES PIÈCES RECOMMANDÉES PAR LE FABRICANT

- 2) Push Switch P.C Board P1022B501C (U), P1022B502C (C, A), P1022B503C (E, V, S), P1022B504C (B), P1022B505C (J)

PUSH SW PCB P1022B501C(U)
 P1022B502C(A,C)
 P1022B503C(E,V,S)
 P1022B504C(B)
 P1022B505C(J)

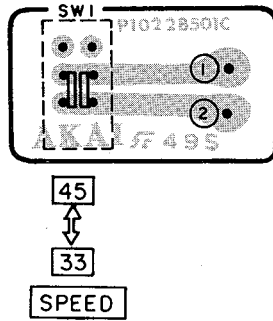

- 3) Quartz Lock P.C Board P1022B501D (U), P1022B502D (C, A), P1022B503D (E, V, S), P1022B504D (B), P1022B505D (J)

QUARTZ LOCK PCB P1022B501D(U)
 P1022B502D(A,C)
 P1022B503D(E,V,S)
 P1022B504D(B)
 P1022B505D(J)

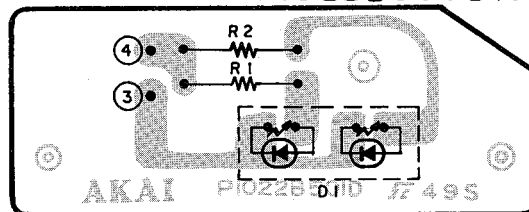

4) Lead Switch P.C Board P1022B501E (U), P1022B502E (C, A), P1022B503E (E, V, S), P1022B504E (B), P1022B505E (J)

LEAD SW PCB P1022B501E(U)
P1022B502E(A,C)
P1022B503E(E,V,S)
P1022B504E(B)
P1022B505E(J)

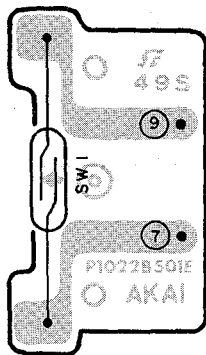

5) Intermediate P.C Board P1022B501F (U), P1022B502F (C, A), P1022B503F (E, V, S), P1022B504F (B), P1022B505F (J)

INTERMEDIATE PCB P1022B501F(U)
P1022B502F(A,C)
P1022B503F(E,V,S)
P1022B504F(B)
P1022B505F(J)

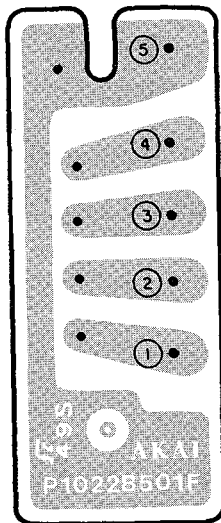

6) Fuse P.C. Board P1022B501B(U)

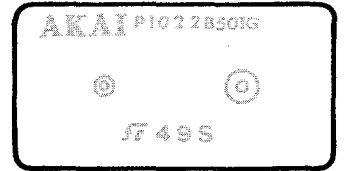
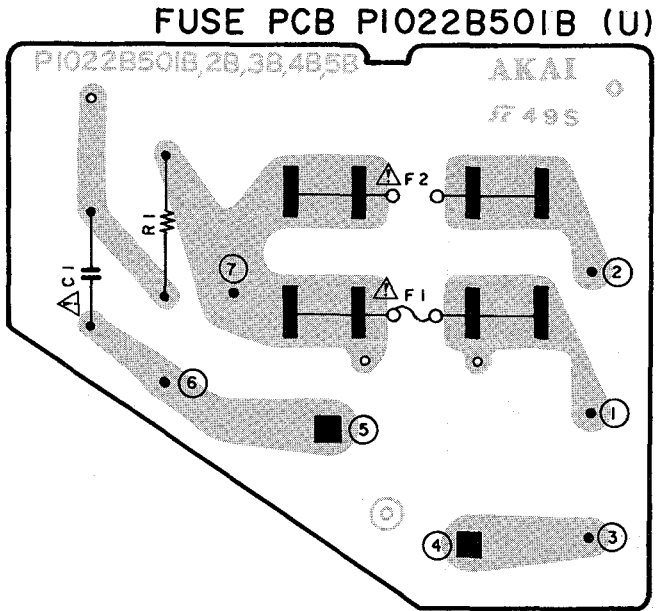

7) Fuse P.C Board P1022B502B (C, A), P1022B505B (J)

WARNING: ΔINDICATES SAFETY CRITICAL COMPONENTS. FOR CONTINUED SAFETY, REPLACE SAFETY CRITICAL COMPONENTS ONLY WITH MANUFACTURER'S RECOMMENDED PARTS.
 AVERTISSEMENT: ΔIL INDIQUE LES COMPOSANTS CRITIQUES DE SÛRETÉ. POUR MAINTENIR LE DEGRÉ DE SÛRETÉ DE L'APPAREIL, NE REMPLACER LES COMPOSANTS DONT LE FONCTIONNEMENT EST CRITIQUE POUR LA SÛRETÉ QUE PAR DES PIÈCES RECOMMANDÉES PAR LE FABRICANT.

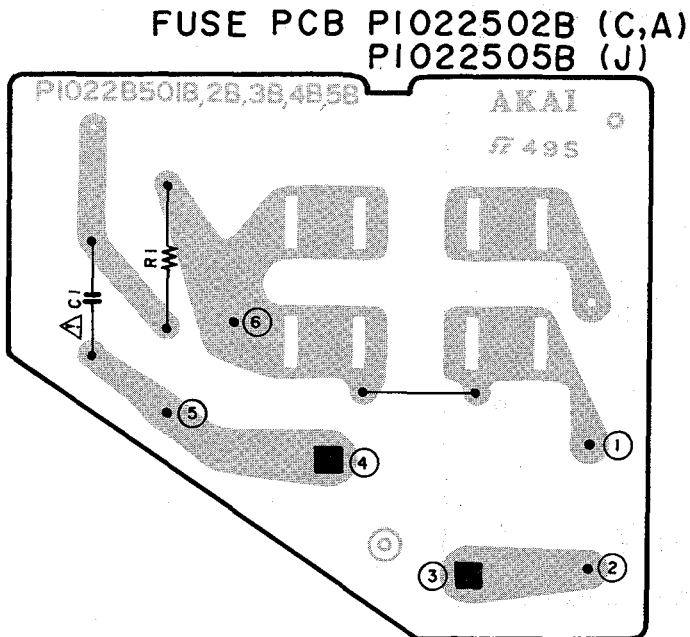

8) Fuse P.C Board P1022B503B (E, V, S)

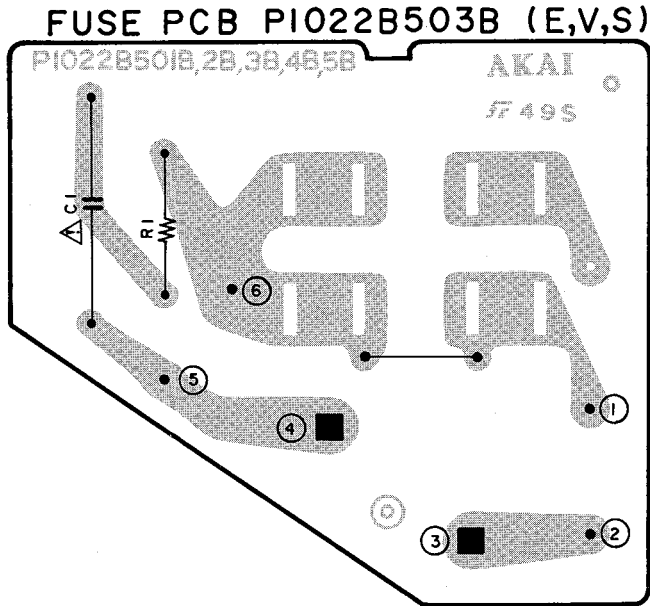

9) Fuse P.C Board P1022B504B (B)

WARNING: Δ INDICATES SAFETY CRITICAL COMPONENTS. FOR CONTINUED SAFETY, REPLACE SAFETY CRITICAL COMPONENTS ONLY WITH MANUFACTURER'S RECOMMENDED PARTS.
 AVERTISSEMENT: Δ IL INDIQUE LES COMPOSANTS CRITIQUES DE SÛRETÉ. POUR MAINTENIR LE DEGRÉ DE SÛRETÉ DE L'APPAREIL, NE REMPLACER LES COMPOSANTS DONT LE FONCTIONNEMENT EST CRITIQUE POUR LA SÛRETÉ QUE PAR DES PIÈCES RECOMMANDÉES PAR LE FABRICANT.

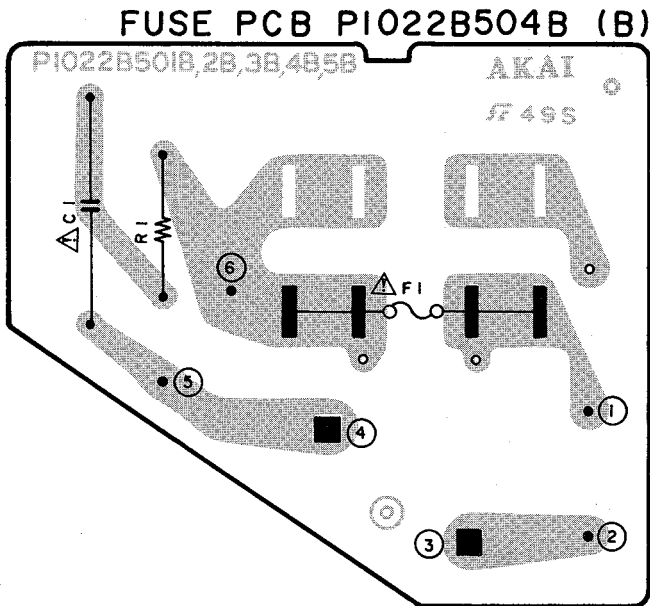

SECTION 2

PARTS LIST

TABLE OF CONTENTS

RECOMMENDED SPARE PARTS 27

1. QUARTZ SERVO P.C BOARD BLOCK 27

2. ASSEMBLY BLOCK 29

3. FINAL ASSEMBLY BLOCK 30

INDEX 31

Resistor and Capacitor which are not listed in this parts list, please refer to
COMMON LIST FOR SERVICE PARTS.

ATTENTION

1. When placing an order for parts, be sure to list the parts no., model no., and description. There are instances in which if any of this information is omitted, parts cannot be shipped or the wrong parts will be delivered.
2. Please be careful not to make a mistake in the parts no. If the parts no. is in error, a part different from the one ordered may be delivered.
3. Because parts number and parts unit supply in the Preliminary Parts List may be partially changed, please use this parts list for all future reference.

HOW TO USE THIS PARTS LIST

1. This Parts List shows the parts that are considered necessary for repairs. Other parts, such as resistors and capacitors, are shown in the "Common List for Service Parts". Select and order such parts from the "Common List for Service Parts".
2. The Recommended Spare Parts List shows those parts in the Parts List which are considered particularly important for service.
3. Parts not shown in the Parts List and "Common List for Service Parts" will not be supplied in principle.
4. How to read list

a) Mechanism Block

b) P.C Board Block

2. HEAD BASE BLOCK

REF. NO.	PARTS NO.	DESCRIPTION
2-1x	BH-T2023A320A	HEAD BASE BLOCK GX-F66R
2-2	HP-H2206A010A	HEAD R/P PR4-8FU C
2-3	ZS-477876	PAN20x03STL CMT
2-4	ZS-536488	BID20x08STL CMT
2-5	ZG-402895	CS ANGLE ADJUST SPRING

SP (Service Parts) Classification

A small "x" indicates the inability to show that particular part in the Photo or Illustration.

This number corresponds with the individual parts index number in that figure

This number corresponds with the Figure Number

6. SYS. CON. P.C BOARD BLOCK

REF. NO.	PARTS NO.	DESCRIPTION
6-1	BA-T2034A070A	PC SYS CON BLK GX-F44R
6-IC1	EI-324536	IC HD14049BP
6-IC2	EI-336801	IC MB8841-564M
6-IC3	EI-331661	IC SN7405N
6-IC4	EI-336725	IC M54527P
6-TR1to4	ET-200985	TR 2SC2603 F,G
6-TR5to28	ET-554657	TR 2SA733A P,Q
6-D1	ED-318292	D SILICON H 1S2473T-77 T26
6-D2to4	ED-308952	D GERMA V 1K34A-LR F07
6-D5to10	ED-318292	D SILICON H 1S2473T-77 T26
6-X1	EI-318384	OSC X'TAL NC-18C 3.579545MHZ

SP (Service Parts) Classification

This reference numbers corresponds with symbol numbers of Schematic Diagrams.

5. Both the kind of part and installation position can be determined by the Parts Number. To determine where a parts number is listed, utilize Parts Index at end of Parts List. It is necessary first of all to find the Parts Number. This can be accomplished by using the Reference Number listed at right of parts number in the Parts Index.

WARNING

⚠ INDICATES SAFETY CRITICAL COMPONENTS. FOR CONTINUED SAFETY, REPLACE SAFETY CRITICAL COMPONENTS ONLY WITH MANUFACTURER'S RECOMMENDED PARTS.

AVERTISSEMENT

⚠ IL INDIQUE LES COMPOSANTS CRITIQUES DE SURETE. POUR MAINTENIR LE DEGRE DE SECURITE DE L'APPAREIL NE REMPLACER LES COMPOSANTS DONT LE FONCTIONNEMENT EST CRITIQUE POUR LA SECURITE QUE PAR DES PIECES RECOMMANDEES PAR LE FABRICANT.

RECOMMENDED SPARE PARTS

Because, if the parts listed bellow are on hand, almost any repair can be accomplished, we suggest that you stock these Recommended Spare Parts Items.

REF. NO.	PARTS NO.	DESCRIPTION
1	BM-P1021A060A	△ MOTOR BLK AP-D210
2	BT-337070	△ TRANS POWER APT310-10 (J)
3	BT-337071	△ TRANS POWER APT310-30 (C, A)
4	BT-337073	△ TRANS POWER APT310-40 (E, V)
5	BT-337074	△ TRANS POWER APT310-50 (B, S)
6	BT-337075	△ TRANS POWER APT310-70 (U)
7	ED-336786	D LED SLP-271D GRN
8	ED-321115	D SILICON H 1S1588LB-5 F10
9	ED-306724	D SILICON S5277B 100/1.0A
10	ED-323353	D ZENER H 05Z12 X
11	ED-323535	D ZENER H 05Z8.2 X
12	EF-300599	△ FUSE FST3100 T 250V 0.40A (F3, 4) (E, V, B, S)
13	EF-300599	△ FUSE FST3100 T 250V 0.40A (F1) (B)
14	EF-327103	△ FUSE TSC A 250V 0.50A (F1, 2) (U)
15	EF-327103	△ FUSE TSC A 250V 0.50A (F3, 4) (U, J)
16	EF-309390	△ FUSE TSC 125V 0.50A (F3, 4) (A, C)
17	EI-336761	IC LA6458S
18	EI-331275	IC TC9142P
19	EI-331274	OSC X'TAL HC-18/U 11.0592MHZ
20	ES-516036	SW LEAD ORD-225
21	ES-326961	SW LEAF MSW-0026TU 01-1 NO
22	ES-326961	SW LEAF MSW-0026TU 01-1 NO
23	ES-336814	SW LEAF MSW-1150NBK 01-1 NO
24	ES-316432	SW MICRO K2 EUC
25	ES-307576	SW PUSH SUJ12 2-02-02N
26	ET-325501	TR 2SA1015 O, Y
27	ET-318237	TR 2SB764 E, F
28	ET-307234	TR 2SC1815 Y, GR
29	ET-325482	TR 2SC1959 Y
30	ET-318239	TR 2SD863 E, F
31	EV-315414	R S-FIX H D8 3P 203
32	EV-315752	R S-FIX H D8 3P 204
33	TP-P1022A070A	GEAR MAIN BLK AP-Q310

1. QUARTZ SERVO P.C BOARD BLOCK

REF. NO.	PARTS NO.	DESCRIPTION
1-1	BA-P1022A020A	PC QUARTZ SERVO BLK AP310 (A)
1-2	BA-P1022A020B	PC QUARTZ SERVO BLK AP-Q310 (E) (E, V, S)
1-3	BA-P1022A020C	PC QUARTZ SERVO BLK AP-Q310-C (U)
1-4	BA-P1022A020D	PC QUARTZ SERVO BLK AP-Q310-C (J)
1-5	BA-P1022A020E	PC QUARTZ SERVO BLK AP-Q310-C (C)
1-6	BA-P1022A020F	PC QUARTZ SERVO BLK AP-Q310-C (B)

QUARTZ SERVO P.C BOARD BLOCK

1-IC1	EI-331275	IC TC9142P
1-IC2	EI-336761	IC LA6458S
1-TR1 to 4	ET-307234	TR 2SC1815 Y, GR
1-TR5	ET-325501	TR 2SA1015 O, Y
1-TR6 to 8	ET-307234	TR 2SC1815 Y, GR
1-TR9	ET-325501	TR 2SA1015 O, Y
1-TR10	ET-307234	TR 2SC1815 Y, GR
1-TR11	ET-325482	TR 2SC1959 Y
1-TR12	ET-318239	TR 2SD863 E, F
1-TR13	ET-318237	TR 2SB764 E, F
1-TR14	ET-318239	TR 2SD863 E, F
1-TR15	ET-318237	TR 2SB764 E, F
1-TR16	ET-318239	TR 2SD863 E, F
1-TR17	ET-318237	TR 2SB764 E, F
1-D1	ED-323535	D ZENER H 05Z8.2 X
1-D2	ED-321115	D SILICON H 1S1588LB-5 F10
1-D3, 4	ED-323353	D ZENER H 05Z12 X
1-D5 to 8	ED-306724	D SILICON S5277B 100/1.0A
1-VR1	EV-315752	R S-FIX H D8 3P 204
1-VR2, 3	EV-315414	R S-FIX H D8 3P 203
1-X1	EI-331274	OSC STAL HC-18/U 11.0592MHZ
1-R8	ER-328067	△ R CB H SNP FS RDS 1/4W 331J
1-C11	EC-313826	C SA V F05 R10K 25DC
1-F3, 4	EF-309390	△ FUSE TSC 125V 0.50A (C, A)
1-F3, 4	EF-300599	△ FUSE FST3100 T 250V 0.40A (E, V, B, S)
1-F3, 4	EF-327103	△ FUSE TSC A 250V 0.50A (U, J)

FUSE P.C BOARD BLOCK

1-F1, 2	EF-327103	△ FUSE TSC A 250V 0.50A (U)
1-F1	EF-300599	△ FUSE FST3100 T 250V 0.40A (B)

PUSH SW P.C BOARD BLOCK

1-SW1	ES-307576	SW PUSH SUJ12 2-02-02N
-------	-----------	------------------------

QUARTZ LOCK P.C BOARD BLOCK

1-D1	ED-336786	D LED SLP-271D GRN
------	-----------	--------------------

LEAD SW P.C BOARD BLOCK

1-SW1	ES-516036	SW LEAD ORD-225
-------	-----------	-----------------

INTERMEDIATE P.C BOARD BLOCK

1-P1	EW-325489	CORD P-54-075 2P AUDIO (U)
1-P1	EW-325492	CORD 2P AUDIO (EXCEPT U)

ASSEMBLY BLOCK

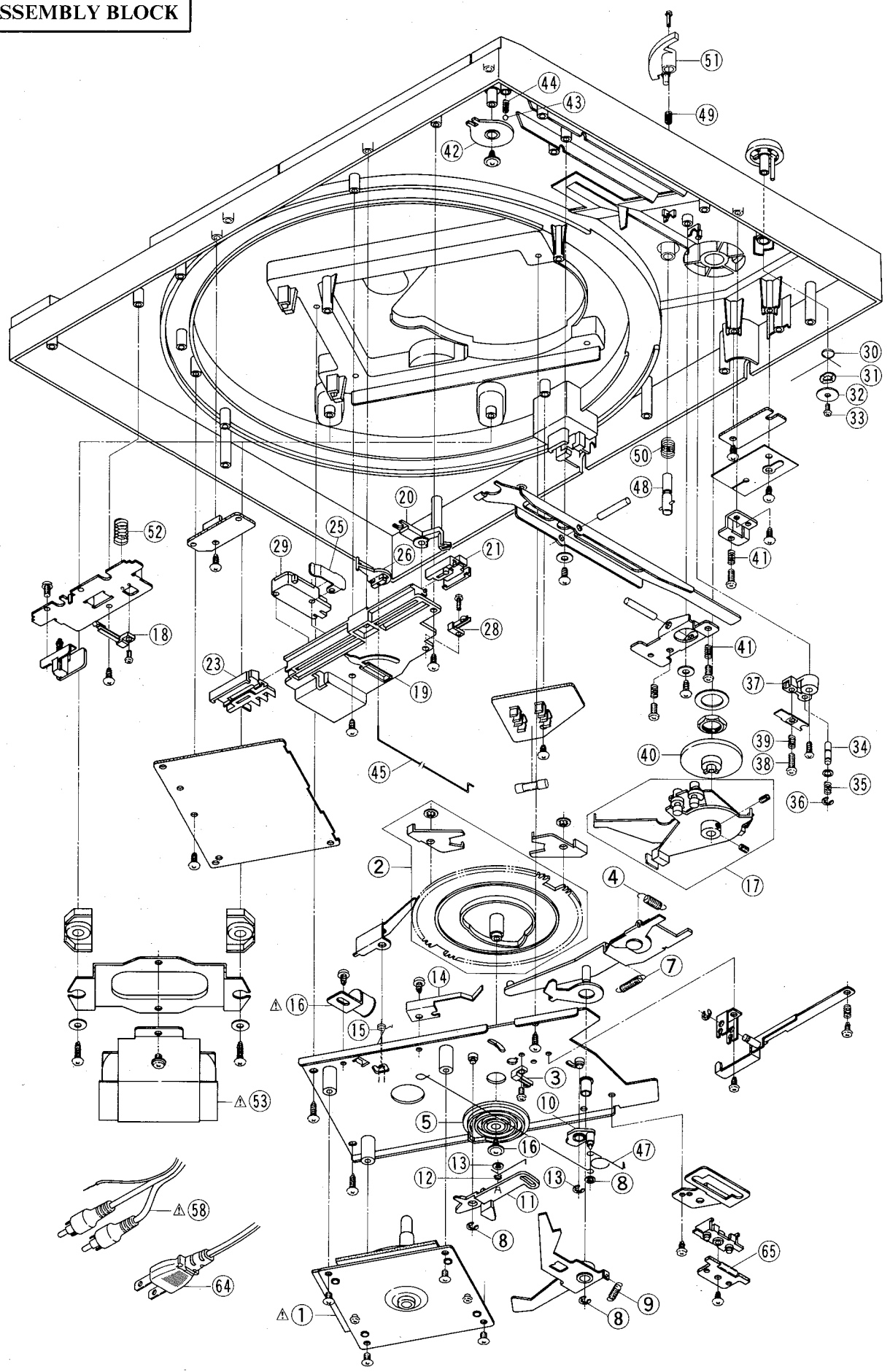

2. ASSEMBLY BLOCK

REF. NO.	PARTS NO.	DESCRIPTION
MOTOR BLOCK		
2-1	BM-P1021A060A	△ MOTOR BLK AP-D210
GEAR MAIN BLOCK		
2-2	TP-P1022A070A	GEAR MAIN BLK AP-Q310
SW LEAF (1) BLOCK		
2-3	ES-326961	SW LEAF MSW-0026TU 01-1 NO (SW902)
CHASSIS AUTO BLOCK		
2-4	ZG-336680	SP PULL (C)
2-5	TP-332475	CAM ROTOR
2-6	ZS-290597	T2BR30×08STL CMT PW100
2-7	ZG-336679B	SP PULL (B)
2-8	ZW-270101	RING E300SUP CMT
2-9	ZG-336679A	SP PULL (A)
2-10	TP-332501	CAM SELECT (A)
2-11	TP-332478	LEVER REJECT
2-12	ZG-332479	SP TORSION
2-13	ZW-340648	RING CS190STL PKR
2-14	ZG-332480	SP PLATE MAIN GEAR
2-15	ZG-336678	SP TORSION REJECT
2-16	EP-P1003A150A	△ PLUNGER ASSY NX-9331H
LEVER PU BLOCK		
2-17	TP-P1022A090A	LEVER PU BLK AP-Q310
SW LEAF (2) BLOCK		
2-18	ES-336814	SW LEAF MSW-1150NBK 01-1 NO (SW903)
CHASSIS SLIDE BLOCK		
2-19	TP-332498A	CHASSIS SLIDE
2-20x	TP-332498B	CHASSIS SLIDE-P
2-21	SK-B332513A1	KNOB (B-1) PART
2-22x	SK-B332513B1	KNOB (B-1) PART
2-23	SK-B332511A	KNOB (A) PART
2-24x	SK-B332511B	KNOB (A)-P PART
2-25	TP-332499	LEVER MICRO SW
2-26	TP-332500	CAM REPEAT
2-27	TP-332477	CAM SELECT (B)
SW LEAF (3) BLOCK		
2-28	ES-326961	SW LEAF MSW-0026TU 01-1 NO (SW904)
SW MICRO BLOCK		
2-29	ES-316432	SW MICRO K2 EUC (SW901)

REF. NO.	PARTS NO.	DESCRIPTION
ASSEMBLY BLOCK		
2-30	ZG-332552B	SP TORSION CANCELLER (B)
2-31	ZW-315478	WAVE WASHER D5 SUS
2-32	ZW-429120	PW23×090×050STL CMT
2-33	ZS-669104	T2PAN23×06STL CMT
2-34	TP-332485	SHAFT BRAKE
2-35	ZG-332497A	SP PUSH (A)
2-36	ZW-357164	RING E230SUP CMT
2-37	TP-332486	HOLDER BRAKE
2-38	ZS-336714	ST BID30×12STL CMT
2-39	ZG-313168	SP C-3.5/0.35-8.0 C-016
2-40	TP-332488	WHEEL BRAKE
2-41	ZG-313168	SP C-3.5/0.35-8.0 C-016
2-42	TP-332496	CAM ELEVATION
2-43	MV-368886	BALL 300STL
2-44	ZG-332497B	SP PUSH (B)
2-45	TP-332502	JOINT (A)
2-46	TP-332503	JOINT (B)
2-47	TP-332504	JOINT (C)
2-48	TP-332505	SHAFT ELEVATION
2-49	ZG-332548	SP PUSH (A)
2-50	ZG-325402	ELEVATION SPRING
2-51	TP-B332568X2	ARM ELEVATION PART
2-52	ZG-325402	ELEVATION SPRING
2-53	BT-337075	△ TRANS POWER APT310-70 (U)
2-54x	BT-337070	△ TRANS POWER APT310-10 (J)
2-55x	BT-337071	△ TRANS POWER APT310-30 (C, A)
2-56x	BT-337073	△ TRANS POWER APT310-40 (E, V)
2-57x	BT-337074	△ TRANS POWER APT310-50 (B, S)
2-58	EW-306428	△ AC CORD 2 CORES KP-205A, VFF J (U)
2-59x	EW-306427	△ AC CORD 2 CORES KP-211, VFF J (J)
2-60x	EW-305691	△ AC CORD 2 CORES KP-8, SPT-1 UC (C, A)
2-61x	EW-313882	△ AC CORD 2 CORES KP-419C, LTCE-2F E (E, V)
2-62x	EW-313884	△ AC CORD 2 CORES GTBS-2F 24/0.20×2 B (B)
2-63x	EW-201515	△ AC CORD 2 CORES KP-560, LTSA-2F S (S)
2-64	EW-325489	CORD P-54-075 2P AUDIO (U)
2-65x	EW-325492	CORD 2P AUDIO (EXCEPT U)
2-66	ES-516036	SW LEAD ORD-225

FINAL ASSEMBLY BLOCK

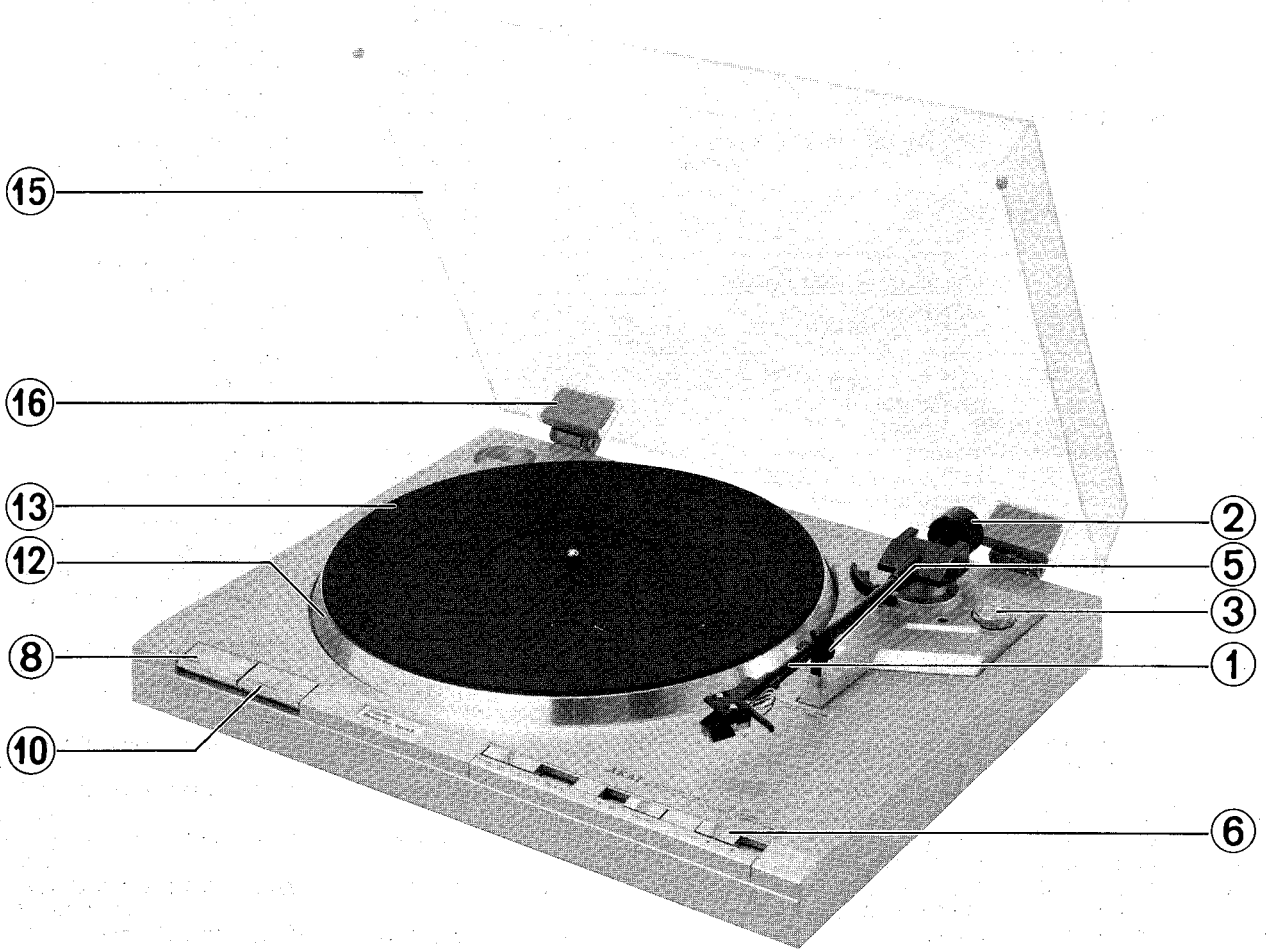

3. FINAL ASSEMBLY BLOCK

REF. NO.	PARTS NO.	DESCRIPTION
3-1	TP-337076	TONE ARM W/SHELL ARM-310
3-2	TP-780045	MAIN WEIGHT
3-3	SK-332551C	KNOB CANCELLER (B)
3-4x	SK-332551B	KNOB CANCELLER-P
3-5	TP-B332571	CLAMPER ARM PART
3-6	SK-B332513A2	KNOB (B-2) PART
3-7x	SK-B332513B2	KNOB (B-2)-P PART
3-8	SK-332560A	KNOB SW (A)
3-9x	SK-332560B	KNOB SW (A)-P
3-10	SK-332560C	KNOB SW (B)
3-11x	SK-332560D	KNOB SW (B)-P
3-12	TP-B332578	PLATTER PART
3-13	TP-332566A	TABLE SHEET (A) (EXCEPT A)
3-14x	TP-332566B	TABLE SHEET (B) (A)
3-15	TP-B332582	DUST COVER PART
3-16	TP-336361	AUTO HINGE OH-5
3-17x	TP-336362	AUDIO HINGE OH-5-BL
3-18x	TP-332577	INSULATOR
3-19x	TP-332577B	INSULATOR (B)

When ordering parts, please quote Parts Number, Description and Model Number.

INDEX

Parts No.	Ref. No. & Symbol No.	Parts No.	Ref. No. & Symbol No.	Parts No.	Ref. No. & Symbol No.	Parts No.	Ref. No. & Symbol No.
BA-P1022A020A	1-1	TP-332478	2-11				
BA-P1022A020B	1-2	TP-332485	2-34				
BA-P1022A020C	1-3	TP-332486	2-37				
BA-P1022A020D	1-4	TP-332488	2-40				
BA-P1022A020E	1-5	TP-332496	2-42				
BA-P1022A020F	1-6	TP-332498A	2-19				
BM-P1021A060A	2-1	TP-332498B	2-20x				
BT-337070	2-54x	TP-332499	2-25				
BT-337071	2-55x	TP-332500	2-26				
BT-337073	2-56x	TP-332501	2-10				
BT-337074	2-57x	TP-332502	2-45				
BT-337075	2-53	TP-332503	2-46				
EC-313826	1-C11	TP-332504	2-47				
ED-306724	1-D5 to 8	TP-332505	2-48				
ED-321115	1-D2	TP-332566A	3-13				
ED-323353	1-D3, 4	TP-332566B	3-14x				
ED-323535	1-D1	TP-332577	3-18x				
ED-336786	1-D1	TP-332577B	3-19x				
EF-300599	1-F1	TP-336361	3-16				
EF-300599	1-F3, 4	TP-336362	3-17x				
EF-309390	1-F3, 4	TP-337076	3-1				
EF-327103	1-F1, 2	TP-780045	3-2				
EF-327103	1-F3, 4	ZG-313168	2-39				
EI-331274	1-X1	ZG-313168	2-41				
EI-331275	1-IC1	ZG-325402	2-52				
EI-336761	1-IC2	ZG-332479	2-12				
EP-P1003A150A	2-16	ZG-332480	2-14				
ER-328067	1-R8	ZG-332497A	2-35				
ES-307576	1-SW1	ZG-332497B	2-44				
ES-316432	2-29	ZG-332548	2-49				
ES-326961	2-28	ZG-332552B	2-30				
ES-326961	2-3	ZG-336678	2-15				
ES-336814	2-18	ZG-336679A	2-9				
ES-516036	1-SW1	ZG-336679B	2-7				
ES-516036	2-66	ZG-336680	2-4				
ET-307234	1-TR 6 to 8	ZS-290597	2-6				
ET-307234	1-TR10	ZS-336714	2-38				
ET-307234	1-TR1 to 4	ZS-669104	2-33				
ET-318237	1-TR13	ZW-270101	2-8				
ET-318237	1-TR15	ZW-315478	2-31				
ET-318237	1-TR17	ZW-340648	2-13				
ET-318239	1-TR14	ZW-357164	2-36				
ET-318239	1-TR12	ZW-429120	2-32				
ET-318239	1-TR16						
ET-325482	1-TR11						
ET-325501	1-TR9						
ET-325501	1-TR5						
EV-315414	1-VR2, 3						
EV-315752	1-VR1						
EW-201515	2-63x						
EW-305691	2-60x						
EW-306427	2-59x						
EW-306428	2-58						
EW-313882	2-61x						
EW-313884	2-62x						
EW-325489	1-P1						
EW-325489	2-64						
EW-325492	1-P1						
EW-325492	2-65x						
MV-368886	2-43						
SK-B332511A	2-23						
SK-B332511B	2-24x						
SK-B332513A1	2-21						
SK-B332513A2	3-6						
SK-B332513B1	2-22x						
SK-B332513B2	3-7x						
SK-332551B	3-4x						
SK-332551C	3-3						
SK-332560A	3-8						
SK-332560B	3-9x						
SK-332560C	3-10						
SK-332560D	3-11x						
TP-B332568X2	2-51						
TP-B332571	3-5						
TP-B332578	3-12						
TP-B332582	3-15						
TP-P1022A070A	2-2						
TP-P1022A090A	2-17						
TP-332475	2-5						
TP-332477	2-27						

SECTION 3

SCHEMATIC DIAGRAM

1. SCHEMATIC DIAGRAM OF ICs 32
2. AP-Q310/C NO. 1640604A SCHEMATIC DIAGRAM 33

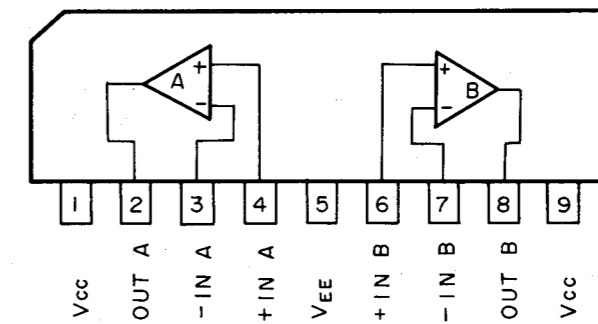

LA6458S

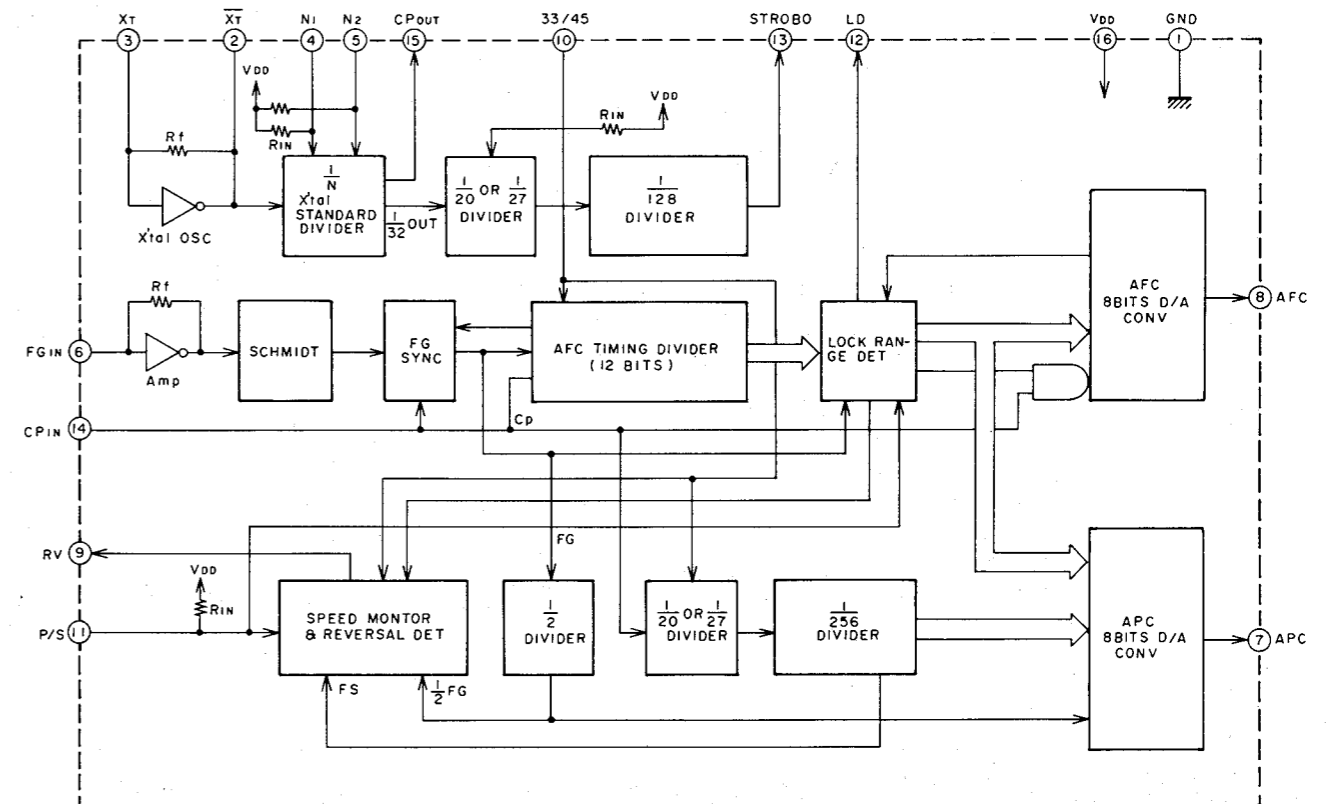

TC9142P

AP-310/C

QUARTZ SERVO PCB

- (U) PIO22B501A [U]
- (C) PIO22B502A [C,A]
- (E) PIO22B503A [E,V,S]
- (B) PIO22B504A [B]
- (J) PIO22B505A [J]

QUARTZ LOCK PCB

- PIO22B501D [U]
- PIO22B502D [C,A]
- PIO22B503D [E,V,S]
- PIO22B504D [B]
- PIO22B505D [J]

LEAD SW PCB

- PIO22B501E [U]
- PIO22B502E [C,A]
- PIO22B503E [E,V,S]
- PIO22B504E [B]
- PIO22B505E [J]

PUSH SW PCB

- PIO22B501C [U]
- PIO22B502C [C,A]
- PIO22B503C [E,V,S]
- PIO22B504C [B]
- PIO22B505C [J]

FUSE PCB
PIO22B501B

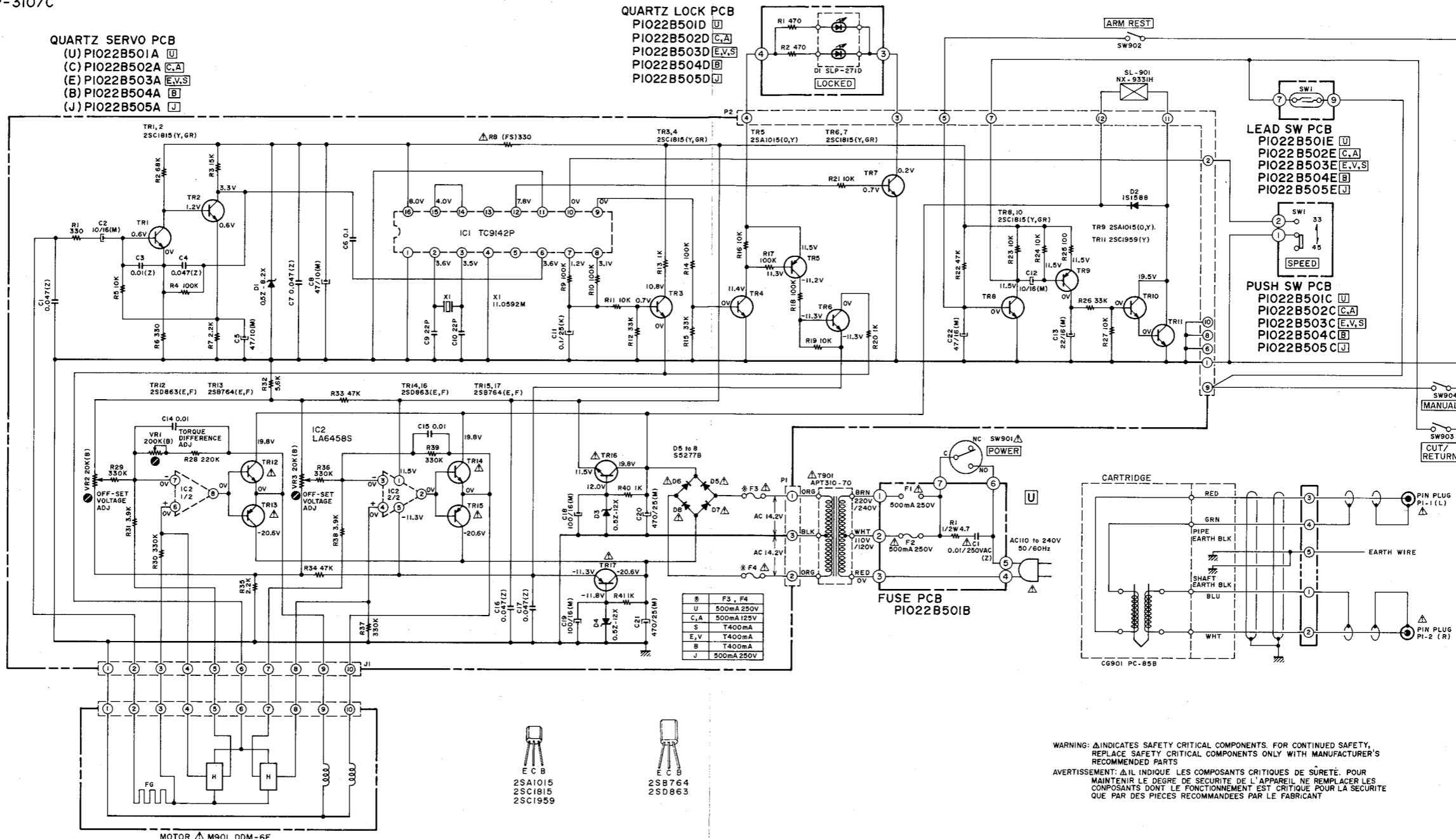

WARNING: Δ INDICATES SAFETY CRITICAL COMPONENTS. FOR CONTINUED SAFETY, REPLACE SAFETY CRITICAL COMPONENTS ONLY WITH MANUFACTURER'S RECOMMENDED PARTS.
 AVERTISSEMENT: Δ IL INDIQUE LES COMPOSANTS CRITIQUES DE SÛRETÉ. POUR MAINTENIR LE DEGRÉ DE SÛRETÉ DE L'APPAREIL NE REMPLACER LES COMPOSANTS DONT LE FONCTIONNEMENT EST CRITIQUE POUR LA SÛRETÉ QUE PAR DES PIÈCES RECOMMANDÉES PAR LE FABRICANT.

NOTE
 UNLESS OTHERWISE SPECIFIED
 ALL RESISTORS IN OHMS 1/4W(J)
 ALL CAPACITORS IN μF 50 WV(J)
 (FS) = FAIL SAFE RESISTORS

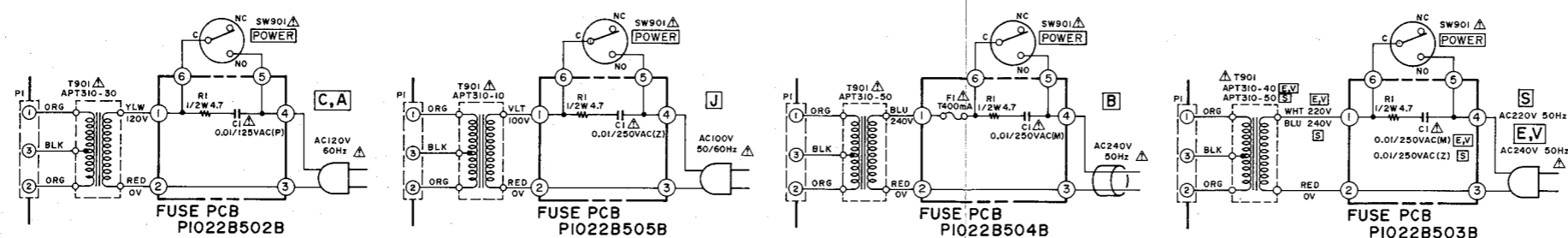

AP-Q310/C
 SCHEMATIC DIAGRAM
 NO. 1640604A

MODEL AP-Q310/CDATE February 1982**I. SPECIFICATIONS**

Turntable	Aluminum alloy die cast
Drive System & Mechanism	Quartz Locked Direct Drive, Fully Automatic
Motor	DC servo motor
Speed	33-1/3 rpm, 45 rpm
Speed Deviation	±0.002%
Wow & Flutter	0.045% (DIN), 0.03% (JIS)
Rumble	48 dB (DIN A), 73 dB (DIN B)
Tone Arm	Static Balanced Type
Effective Arm Length	220 mm
Stylus Pressure	
Adjustment Range	0 to 2.5 grams
Applicable Cartridge	
Weight	3 to 8 grams
Arm Lifter	Oil damped
Overhang	17.5 mm
Offset Angle	24°
Horizontal Tracking	
Error Angle	+2°40' (Outside) -1° (Inside)
Cartridge	VM (Dual Magnet) type (Model AP-Q310 does not include cartridge.)
Optimal Stylus Pressure	2 grams
Output Voltage	5 mV (DIN)
Channel Separation	20 dB
Frequency Response	20 to 20,000 Hz
Cartridge Load Impedance	47 kohms
Static Vertical Compliance	16 x 10 ⁻⁶ cm/dyne
Static Horizontal Compliance	12.5 x 10 ⁻⁶ cm/dyne
Dynamic Vertical compliance	4.5 x 10 ⁻⁶ cm/dyne
Dynamic Horizontal Compliance	4.5 x 10 ⁻⁶ cm/dyne
Power Requirements	100V, 50/60 Hz for Japan 120V, 60 Hz for USA and Canada 220V, 50 Hz for Europe except UK 240V, 50 Hz for UK and Australia 110-120V/220-240V, 50/60 Hz switchable for other countries
Power Consumption	6W
Dimensions	440(W) x 98(H) x 359(D) mm (17.3 x 3.9 x 14.1 inches)
Weight	5.4 kg (11.9 lbs)

* For improvement purposes, specifications and design are subject to change without notice.

II. VOLTAGE AND CYCLE CONVERSION

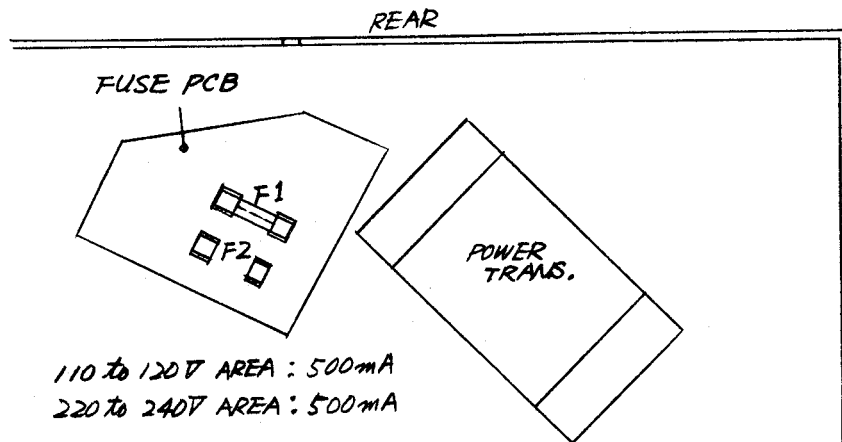

Fig. 1 Voltage Conversion (U Model only)

1. VOLTAGE CONVERSION

Models for Japan, Canada, USA, Europe, UK and Australia are not equipped with this facility.

Each unit is preset at the factory depending on its destination, but some units can be converted to 110-120V or to 220-240V as required.

If voltage change is necessary, this can be accomplished as follows:

- 1) Disconnect the power cord.
- 2) Remove the bottom cover.
- 3) Remove the existing Line Voltage Fuse and insert the required Line Voltage Fuse in the proper fuse holder according to the printed instructions.

2. CYCLE CONVERSION

With DC servo motor, cycle conversion is not necessary.

III. ORDINARY ADJUSTMENT

1. STYLUS PRESSURE ADJUSTMENT

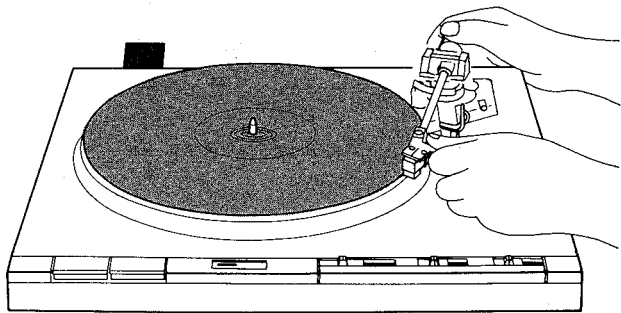

Fig. 2

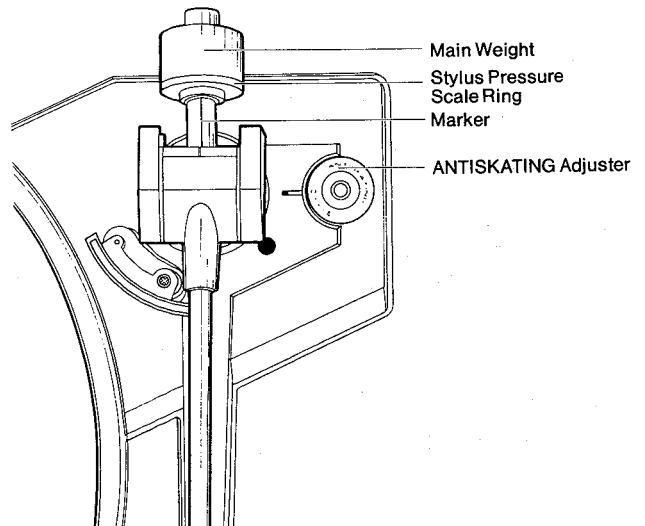

Fig. 3

- 1) Connect the Power Cord.
- 2) Set the ANTISKATING adjuster to "0".
- 3) Set the CUE lever to ▼ .
- 4) Set the SIZE/MANUAL Mode selector to MANUAL.
- 5) Unlock the Tone Arm and bring it towards the Platter.
 - * Remove the Stylus Guard being careful not to damage the Stylus.
- 6) Set the POWER/REPEAT selector to "1".
 - The Tone Arm Lifter will be lowered.
- 7) With the Tone Arm held midway between the Tone Arm Rest and the rim of the Platter, adjust the Main Weight until the Tone Arm is in perfect horizontal balance.
- 8) Without moving the Main Weight, rotate the Stylus Pressure Scale Ring only to match the "0" mark with the mark on the weight shaft.
- 9) Depress the CUT/RETURN switch.
- 10) Lock the Tone Arm in place and rotate the Main Weight counterclockwise, as viewed from the front (the Stylus Pressure Scale Ring will move with it), until the desired Stylus Pressure Scale indication is at the mark on the shaft. The range of adjustment is from 0 to 2.5 grams.
 - * For AP-Q310C only: The recommended stylus pressure for the cartridge supplied, PC-85, is 2 grams.
- 11) Set the ANTISKATING adjuster to the corresponding stylus pressure.

2. OVERHANG (Not necessary for AP-Q310C)

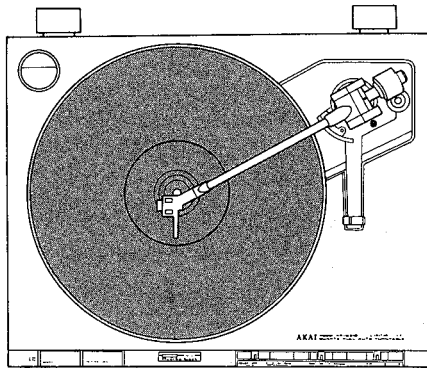

Fig. 4

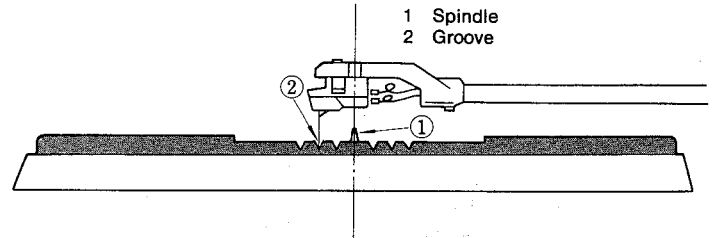

Fig. 5

The Distance between the Spindle and the Stylus when the Tone Arm is centered over the Platter is known as the Overhang.

Different cartridges require different Overhang Adjustments.

For your convenience, the Rubber Mat has indicator grooves at the center to facilitate Overhang Adjustment.

- 1) Center the Tone Arm over the Platter.
- 2) Adjust the Cartridge so that the Stylus position is even with the Groove for Overhang Adjustment (middle groove ring).

* The Cartridge position can be adjusted by resetting the Cartridge Re-Setting Screws in the Head Shell.

IV. MECHANICAL ADJUSTMENT

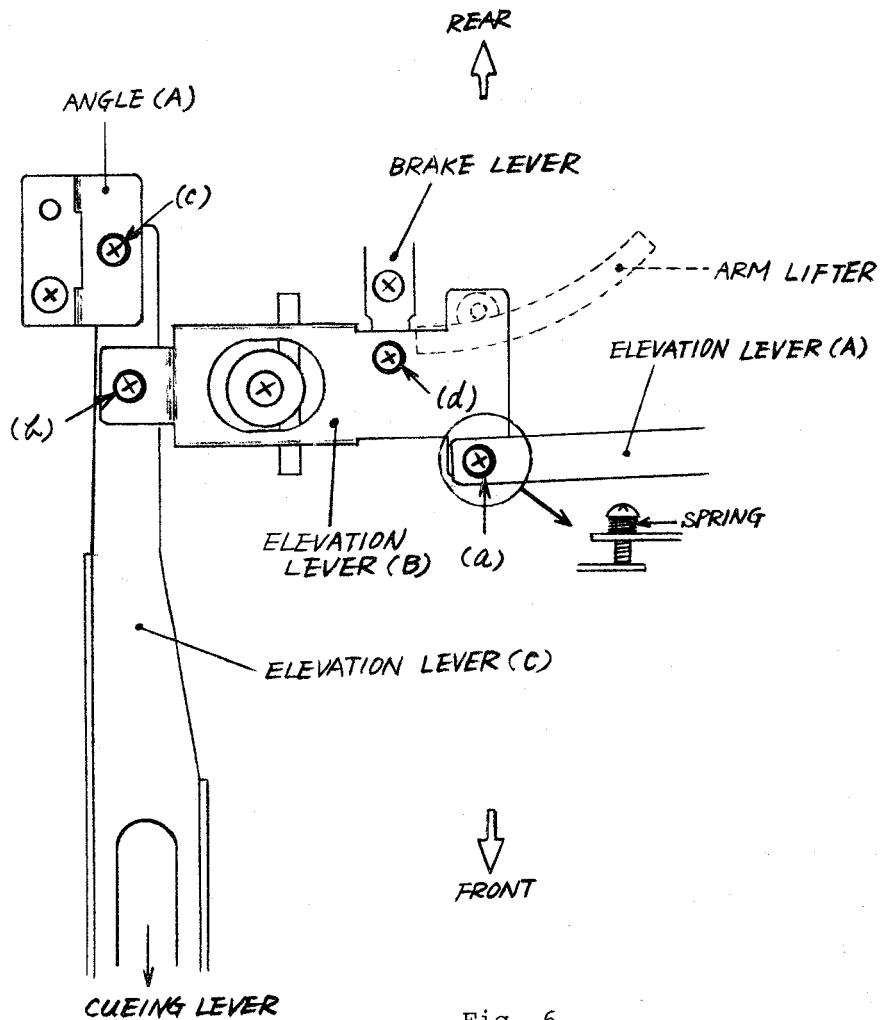

Fig. 6

1. TONE ARM LIFTER ADJUSTMENT (Fig. 6)

- 1) The height of the stylus point is adjusted when the arm is lifted in AUTO PLAY and manually (cueing lever).
 - a) Adjust the size selector to 17 cm.
 - b) Remove the rubber mat and platter and turn the main gear 3/4 counterclockwise. (Lead in → arm down → arm up → when returning)
 - c) Loosen the screws (b) and (c).
 - d) Check that the spring of screw (a) is fully tightened.
 - e) Set the cueing lever to ▲ (UP).
 - f) Tighten the screw (b) slowly so that the stylus point will be about 1-2 mm higher than when the stylus is lifted in AUTO PLAY. (Check by moving the cueing lever ▲ (UP) ... ▼ (DOWN).
 - g) Tighten the screw (c) until the end almost touches the elevation lever (c). (Cueing lever: ▲)

- h) While repeating the operation of ∇ (UP) \leftrightarrow ∇ (DOWN) of the cueing, tighten the screw (c) until the stylus point hardly changes.
- i) Have the auto return finished by turning the main gear 1/4.
- j) Paintlock the screws (a), (b) and (c).

2) Tone Arm Lifter Height Adjustment

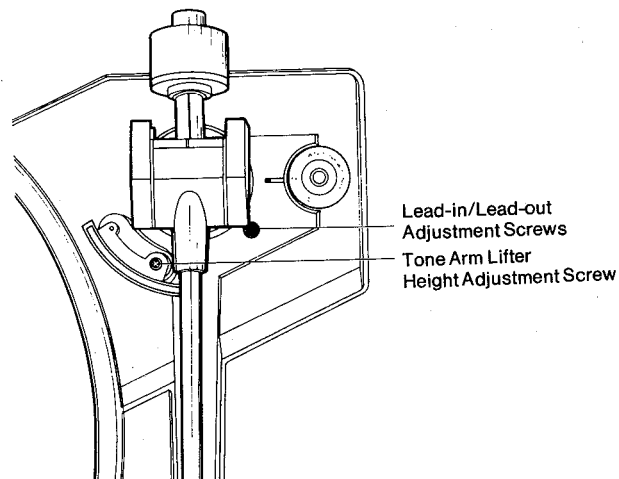

Fig. 7

With the Tone Arm in the up position, the Stylus should be 5 to 7 mm above the surface of the record. If it is not, adjust the height by adjusting the Tone Arm Lifter Height Adjustment Screw.

clockwise: down

Counterclockwise: up

2. TONE ARM BRAKE ADJUSTMENT

The arm brake the horizontal movement of the arm to have it move smoothly when AUTO LEAD-IN and AUTO RETURN. AP-Q310 uses the friction of the felt.

- 1) Carry out 1-1) a) and b).
- 2) Provide the horizontal balance of the tone arm. (It means that the tone arm is away from the arm lifter).
- 3) Adjust the antiskating adjuster to 2.
- 4) When the screw (d) is loosened, the tone arm starts to move toward the periphery (the situation where the brake will not be functioning).
- 5) Have the tone arm move near to the outer periphery of a 17 cm record, and tighten the screw (d) slowly to the point where it does not move toward the outer periphery any more even the hand is removed (point where the brake starts to function).
- 6) From the status of 5), tighten the screw (d) one more turn clockwise.
- 7) Paintlock the screw (d).

3. LEAD-IN/LEAD-OUT ADJUSTMENTS (Fig. 7)

1) Lead-in position

- a) Place a record on the Platter.
- b) Auto-play the record and confirm where the Stylus descends.
- c) Depress the CUT/RETURN switch to return the Tone Arm to the Tone Arm Rest.
- d) Move the Tone Arm towards the Platter until the Lead-in Adjustment Screw is visible.
- e) Turn the Lead-in Adjustment Screw with a screwdriver:
Clockwise: To make the Stylus descend towards the Spindle.
Counterclockwise: To make the Stylus descend away from the Spindle.

2) Lead-out position

- a) Auto-play the record and confirm where auto-return begins.
- b) Turn the Lead-out Adjustment Screw with a screwdriver:
* The Lead-out Adjustment Screw is visible without moving the Tone Arm.
Clockwise: To delay auto-return.
Counterclockwise: To hasten auto-return.

NOTE: Carry out both adjustments little at a time and confirm the position after each adjustment.

4. RETURN PLUNGER POSITION ADJUSTMENT

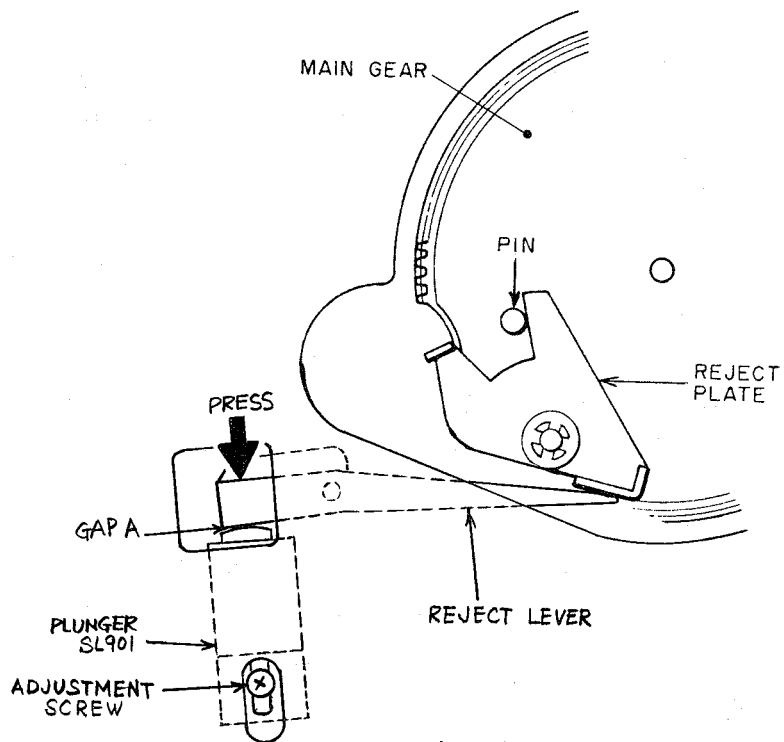

Fig. 8

Press the reject lever down with a finger until the reject plate touches the main gear pin. Operate the plunger (SL901) in this position and adjust the installation screw at exactly the point where the gap A between the reject lever and plunger disappears. (Refer to Fig. 8)
After adjustment, confirm that the Auto Play is operating.

V. ELECTRICAL ADJUSTMENT

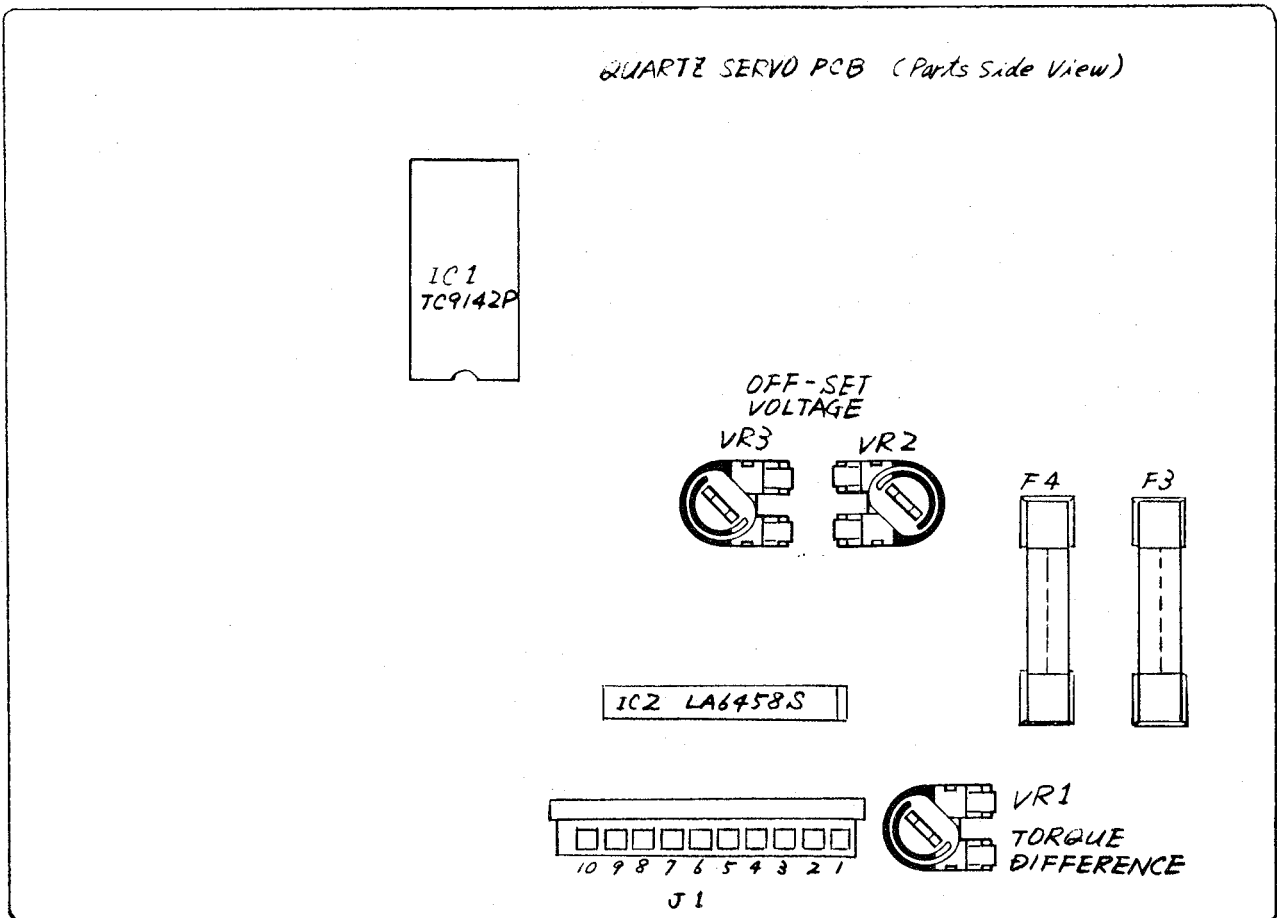

Fig. 9

1. OFF-SET VOLTAGE ADJUSTMENT (VR2, 3) AND TORQUE DIFFERENCE ADJUSTMENT (VR1)
 - 1) Disconnect the motor connection cord (J1).
 - 2) Short connector (J1) pins (7), (8) and (1).
 - 3) Set VR1 to the center.
 - 4) Turn the power switch ON.
 - 5) Connect an digital voltmeter to terminal (10) of connector J1 and adjust VR3 until it reads -120 mVDC.
 - 6) Turn the power switch OFF.
 - 7) Short connector (J1) pins (4), (5) and (1).
 - 8) Turn the power switch ON.
 - 9) Connect a digital voltmeter to terminal (9) of connector J1 and adjust VR2 until it reads -120 mVDC.
 - 10) Turn the power switch OFF and connect the motor connection wire to connector (J1).
 - 11) Connect an oscilloscope to (9) and (10) of connector (J1).

- 12) Turn the power switch ON.
- 13) Set the SIZE/MANUAL selector to MANUAL.
- 14) Turn the power switch ON to rotate platter.
- 15) Adjust VR1 so that the voltage of connector (J1)'s (9) and (10) may be the same. (The voltage indicated in (9) and (10) is for switching motor coil, and its frequency is very low.

2. WOW AND FLUTTER CONFIRMATION

- 1) Playback the test record (3,000 Hz).
- 2) Confirm that the Wow and Flutter is within 0.03% (JIS).
- 3) If not, re-adjust VR1, VR2 and VR3.

VI. SCHEMATIC DIAGRAM OF ICS

LA6458S

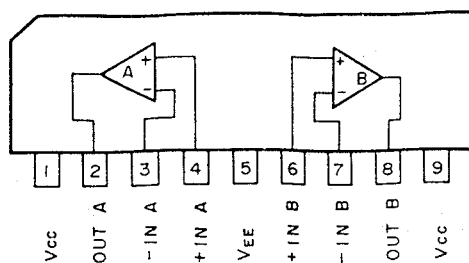

- C** QUARTZ SERVO (C) P.C.BOARD (P1022B502A)
- E** QUARTZ SERVO (E) P.C.BOARD (P1022B503A)
- J** QUARTZ SERVO (J) P.C.BOARD (P1022B504A)
- U** QUARTZ SERVO (U) P.C.BOARD (P1022B501A)

- A** P1022B502D
- C** P1022B503D
- E** P1022B504D
- J** P1022B505D
- U** P1022B501D

- A** P1022B502E
- E** P1022B503E
- U** P1022B501E

- J** P1022B505E
- B** P1022B504E

- A** P10223502C
- S** P10223503C
- U** P10223501C
- J** P10223505C
- B** P10223504C

	F1	F2	F3	F4
U	500mA 250V	500mA 250V	500mA 250V	500mA 250V
B	7A00mA	7A00mA	7A00mA	7A00mA
C	500mA 125V	500mA 125V	500mA 125V	500mA 125V
E	7A00mA	7A00mA	7A00mA	7A00mA
J	7A00mA	7A00mA	7A00mA	7A00mA
U	500mA 250V	500mA 250V	500mA 250V	500mA 250V

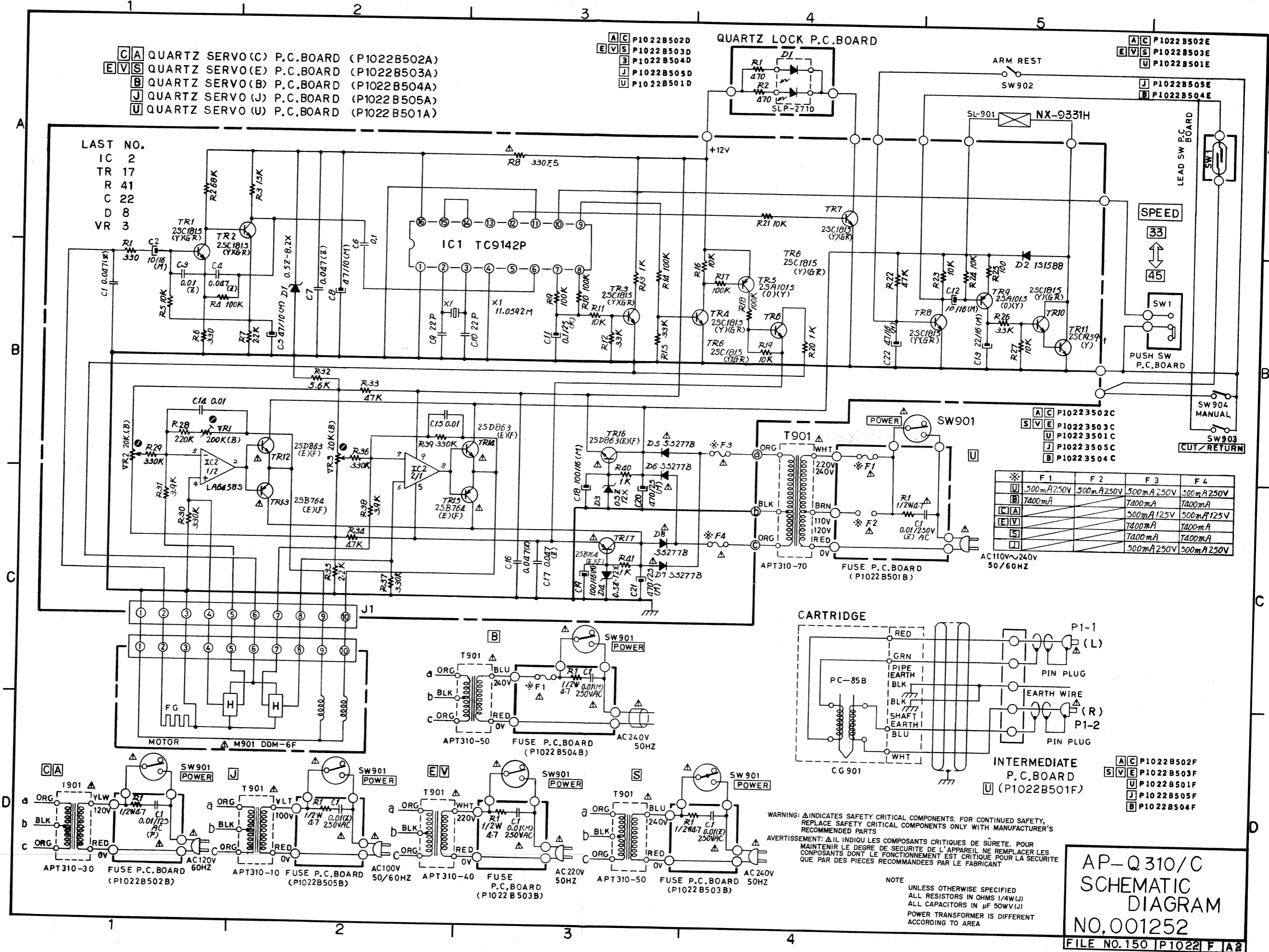

LAST NO.
 IC 2
 TR 17
 R 41
 C 22
 D 8
 VR 3

QUARTZ LOCK P.C. BOARD

CARTRIDGE

INTERMEDIATE P.C. BOARD

WARNING: Δ INDICATES SAFETY CRITICAL COMPONENTS. FOR CONTINUED SAFETY, REPLACE SAFETY CRITICAL COMPONENTS ONLY WITH MANUFACTURER'S RECOMMENDED PARTS.
 AVERTISSEMENT: Δ IL INDIQUE LES COMPOSANTS CRITIQUES DE SÛRETÉ. POUR MAINTENIR LE DEGRÉ DE SÛRETÉ DE L'APPAREIL, NE REMPLACER LES COMPOSANTS DONT LE FONCTIONNEMENT EST CRITIQUE POUR LA SÛRETÉ QUE PAR DES PIÈCES RECOMMANDÉES PAR LE FABRICANT.

NOTE
 UNLESS OTHERWISE SPECIFIED
 ALL RESISTORS IN OHMS 1/4W(J)
 ALL CAPACITORS IN μF 50WV(J)
 POWER TRANSFORMER IS DIFFERENT
 ACCORDING TO AREA

AP-Q310/C
 SCHEMATIC
 DIAGRAM
 NO.001252
 FILE NO.150 P1022 F A2

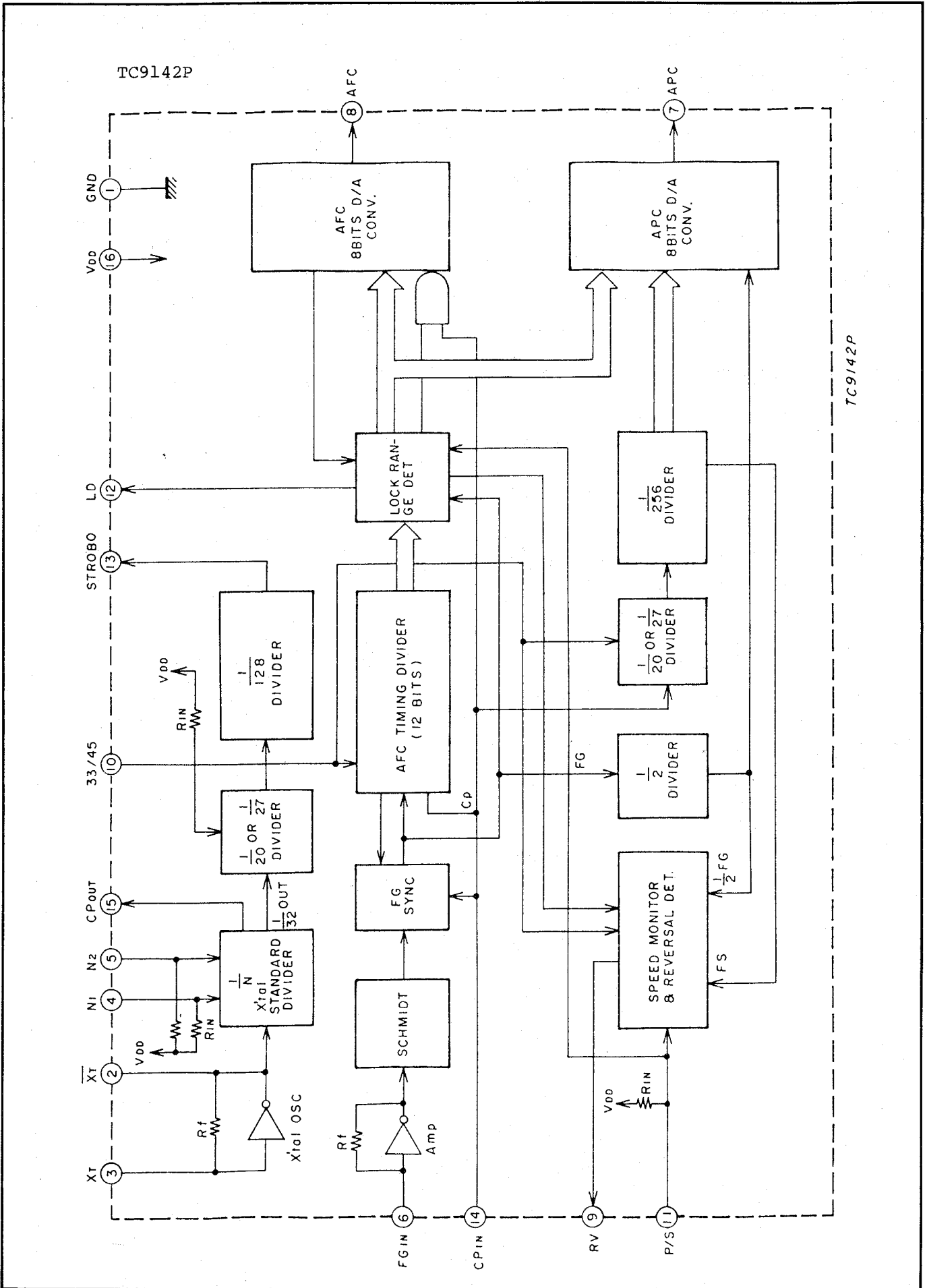

MODEL AP-Q41/CDATE March 1982**I. SPECIFICATIONS**

Turntable	310 mm aluminum alloy die cast
Drive System & Mechanism	Quartz Locked Direct Drive, Fully Automatic
Motor	DC Servo Motor
Speed	33-1/3 rpm, 45 rpm
Speed Deviation	±0.002%
Wow & Flutter	0.025% (WRMS)
Rumble	78 dB (DIN B), 48 dB (DIN A)
Tone Arm	Static-balanced type with electronic inside force canceller
Effective Arm Length	220 mm
Stylus Pressure	
Adjustment Range	0 to 2.5 grams
Applicable Cartridge	
Weight	3 to 8 grams
Arm Lifter	Oil damped
Overhang	17.5 mm
Shell Weight	3.6 grams
Cartridge	VMS type (Ortofon: SMB-12) (Model AP-Q41 does not include cartridge.)
Optimal Stylus Pressure	1.5 grams
Output Voltage	4.3 mV (DIN)
Channel Separation	25 dB
Power Requirements	100V, 50/60 Hz for Japan 120V, 60 Hz for USA and Canada 220V, 50 Hz for Europe except UK 240V, 50 Hz for UK and Australia 110-120V/220-240V, 50/60 Hz switchable for other countries
Power Consumption	14W (J), 12W (Others)
Dimensions	440(W) x 97(H) x 342(D) mm (17.3 x 3.8 x 13.5 inches)
Weight	6.1 kg (13.4 lbs)

* For improvement purposes, specifications and design are subject to change without notice.

II. VOLTAGE AND CYCLE CONVERSION

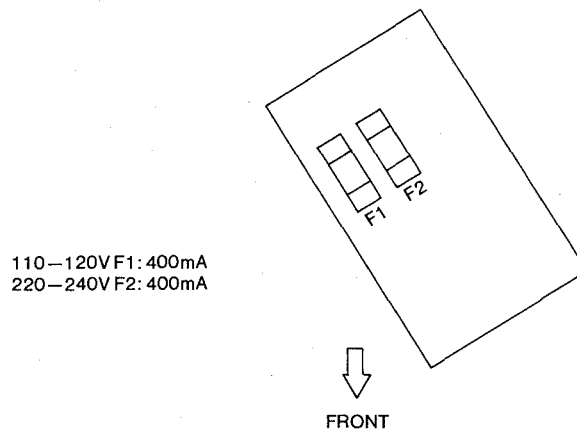

Fig. 1 Voltage Conversion (U Model only)

1. VOLTAGE CONVERSION

Models for Canada, USA, Europe, UK, Australia and Japan are not equipped with this facility.

Each unit is preset at the factory depending on its destination, but some units can be converted to 110-120V or to 220-240V as required.

If voltage change is necessary, this can be accomplished as follows:

1. Disconnect the power cord.
2. Remove the bottom cover.
3. Remove the existing Line Voltage Fuse and insert the required Line Voltage Fuse in the proper fuse holder according to the printed instructions.

2. CYCLE CONVERSION

With DC servo motor, cycle conversion is not necessary.

III. ORDINARY ADJUSTMENT

1. STYLUS PRESSURE ADJUSTMENT

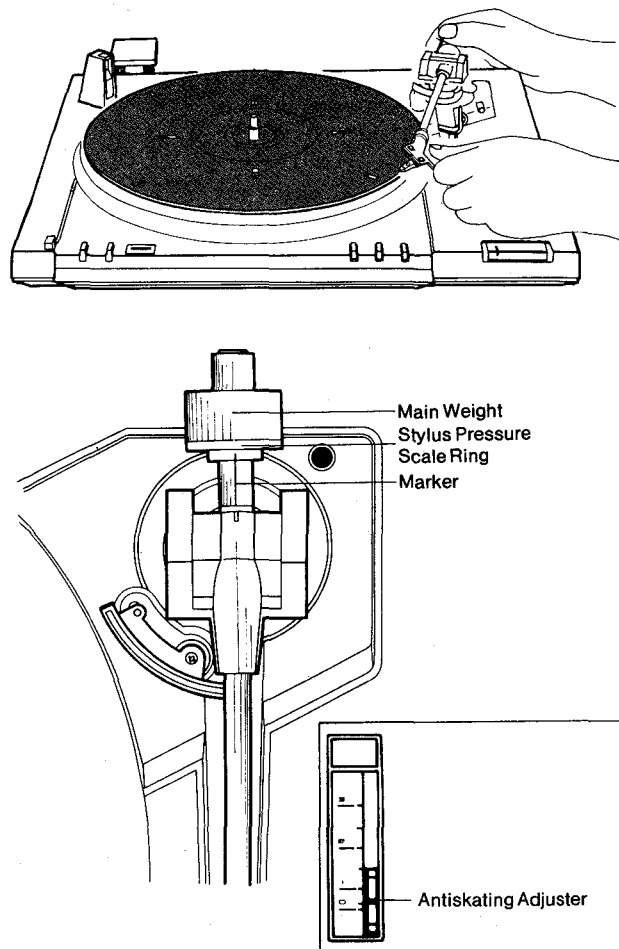





Fig. 2 Stylus Pressure Adjustment

1. Connect power cord and turn ON () the POWER switch.
2. Set the Antiskating Adjuster to "0".
3. Unlock the Tone Arm and bring it towards the Platter.
 - * Remove the Stylus Guard being careful not to damage the Stylus.
4. With the Tone Arm held midway between the Tone Arm Rest and the rim of the Platter, depress the Cueing ( / ) button, to lower the Tone Arm Lifter.
5. Adjust the Main Weight until the Tone Arm is in perfect horizontal balance.
6. Without moving the Main Weight, rotate the Stylus Pressure Scale Ring only to match the "0" mark with the mark on the weight shaft.
7. Return the Tone Arm to the Tone Arm Rest.
 - * The Tone Arm Lifter will rise.

8. Lock the Tone Arm in place and rotate the Main Weight counterclockwise, as viewed from the front (the Stylus Pressure Scale Ring will move with it), until the desired Stylus Pressure Scale indication is at the mark on the shaft.

The range of adjustment is from 0 to 2.5 grams.

* For AP-Q41C only: The recommended stylus pressure for the cartridge supplied, SMB-12, is 1.5 grams.

9. Set the Antiskating Adjuster to the corresponding stylus pressure.

2. OVERHANG (Not necessary for AP-Q41C)

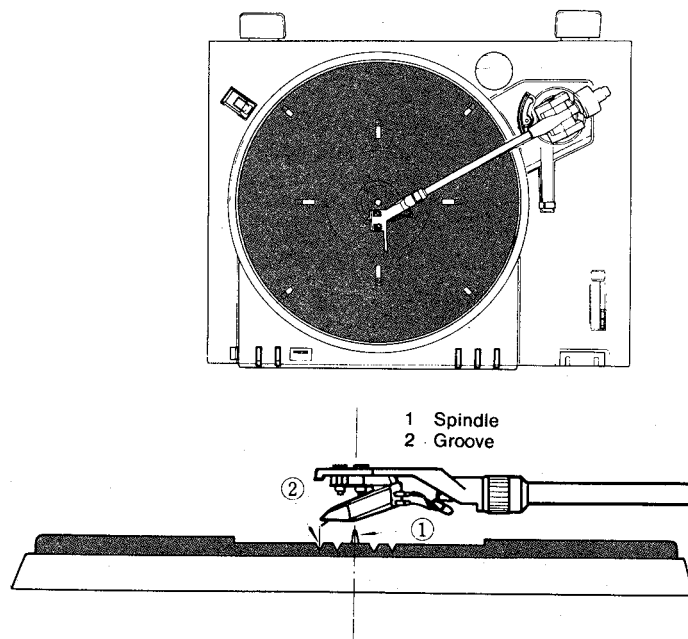

Fig. 3 Overhang Adjustment

The distance between the Spindle and the Stylus when the Tone Arm is centered over the Platter is known as the Overhang.

Different cartridges require different Overhang Adjustments.

For your convenience, the Rubber Mat has indicator grooves at the center to facilitate Overhang Adjustment.

1. Center the Tone Arm over the Platter.
2. Adjust the Cartridge so that the Stylus position is even with the Groove for Overhang Adjustment.

* The Cartridge position can be adjusted by resetting the Cartridge Re-Setting Screws in the Head Shell.

3. TONE ARM LIFTER HEIGHT ADJUSTMENT

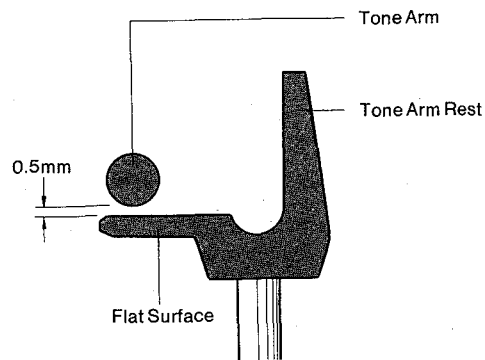

Fig. 4 Toen Arm Lifter Height Adjustment

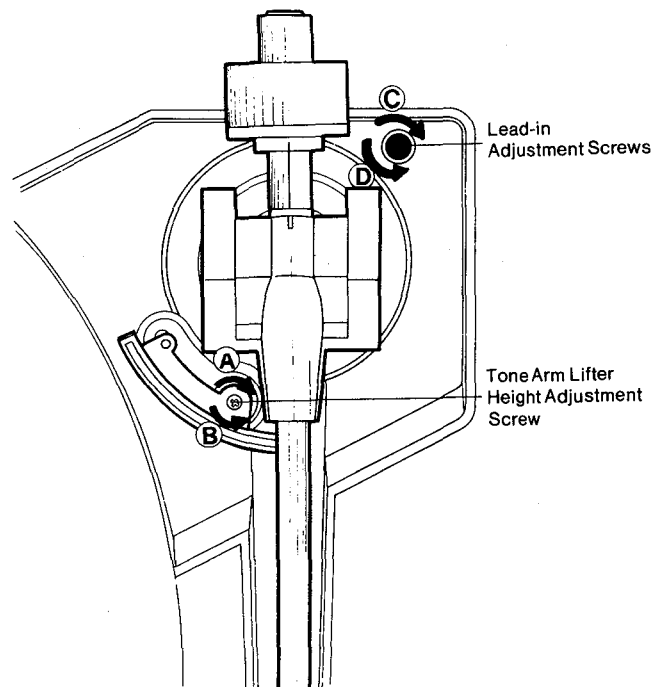

Fig. 5 Tone Arm Height Adjustment, Lead-IN Adjustment

With the Tone Arm in the up-position, the Stylus should be more than 4 mm above the surface of the record and the Tone Arm should be 0.5 mm above the flat surface of the Tone Arm Rest.

If it is not, adjust the height by adjusting the Tone Arm Lifter Height Adjustment Screw.

- (A) Clockwise : down
- (B) Counterclockwise : up

4. LEAD-IN POSITION ADJUSTMENT (Refer to Fig. 5)

1. Place a record on the Platter.
2. Auto-play the record and confirm where the Stylus descends.
3. Depress the START/CUT button to return the Tone Arm to the Tone Arm Rest.
4. Turn the Lead-in Adjustment Screw with a screwdriver:
 - Ⓒ Clockwise : To make the Stylus descend towards the Spindle.
 - Ⓓ Counterclockwise : To make the Stylus descend away from the Spindle.

NOTE: Do not turn the screw too far.

Carry out the adjustment little at a time and confirm the position after each adjustment.

IV. ELECTRICAL ADJUSTMENT

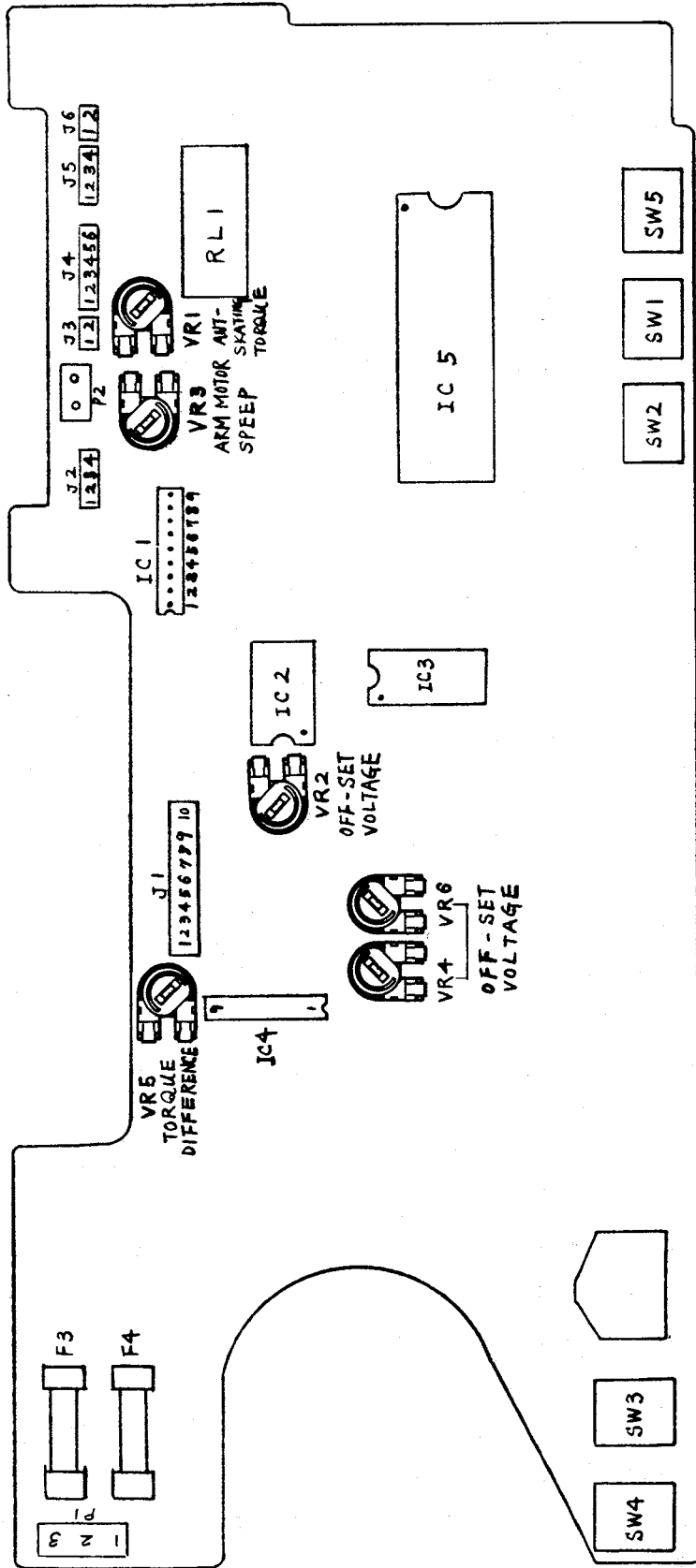

Fig. 6 Servo/Syscon PCB (Parts Side View)

1. OFF-SET VOLTAGE ADJUSTMENT (VR2)
 - 1) Turn on the Power Switch.
 - 2) Lock the Tone Arm to Tone Arm Rest.
 - 3) Connect an digital voltmeter to (8) of IC1 and adjust VR2 until it reads 0V.
2. ARM MOTOR SPEED ADJUSTMENT (VR3)
 - 1) Turn on the Power Switch.
 - 2) Set the Tone Arm to Tone Arm Rest.
 - 3) Connect a digital voltmeter to (2) of Connector J2.
 - 4) Depress the SLOW REV (> >>) Button, and adjust VR3 until it reads 7V.
3. ANTI-SKATING TORQUE ADJUSTMENT (VR1)
 - 1) Turn on the Power Switch.
 - 2) Set the ELECTRONIC ANTI SKAKE VR to Maximum ("3").
 - 3) With the Tone Arm held midway between the Tone Arm Rest and the rim of the Platter, depress the Cueing (▼ / ▼) Button, to lower the Tone Arm Lifter.
 - 4) Connect a digital voltmeter to (2) of Connector J2 and adjust VR1 until it reads 0.6V.
4. OFF-SET VOLTAGE ADJUSTMENT (VR4, VR6) AND TORQUE DIFFERENCE ADJUSTMENT (VR5)
 - 1) Disconnect the motor connection cord (J1).
 - 2) Short connector (J1) pins (7), (8) and (1).
 - 3) Set VR5 to center position.
 - 4) Turn on the Power Switch.
 - 5) Depress the Forward (<< <) button to bring the Tone Arm over the record. The Platter will begin ratating.
 - 6) Connect a digital voltmeter to (10) of connector J1 and adjust VR6 until it reads -120 mDC.
 - 7) Depress the START/CUT Button to return the Tone Arm to the Tone Are Rest.
 - 8) Turn off the Power Switch.
 - 9) Short connector J1 pins (4), (5) and (1).
 - 10) Turn on the Power Switch.
 - 11) Depress the Forward (<< <) button to bring the Tone Arm over the record. The Platter will begin ratating.
 - 12) Connect a digital voltmeter to (9) of connector J1 and adjust VR4 until it reads -120 mDC.
 - 13) Depress the START/CUT Button to return the Tone Arm to the Tone Arm Rest.

- 14) Turn off the Power Switch.
- 15) Connect the motor connection wire to connector J1.
- 16) Connect an oscilloscope to ⑨ and ⑩ of connector J1.
- 17) Depress the Forward (<<< <) Button to bring the Tone Arm over the record. The Platter will begin rotating.
- 18) Adjust VR5 so that the voltage of connector J1's ⑨ and ⑩ may be same. (The voltage indicated in ⑨ and ⑩ is for switching motor coil, and its frequency is very low)

5. WOW AND FLUTTER CONFIRMATION

- 1) Playback the test record (3,000 Hz).
- 2) Confirm that the Wow and Flutter is within 0.025% (WRMS).
- 3) If not, re-adjust VR5, VR4 and VR6.

V. SCHEMATIC DIAGRAM OF ICS

TC4016BP

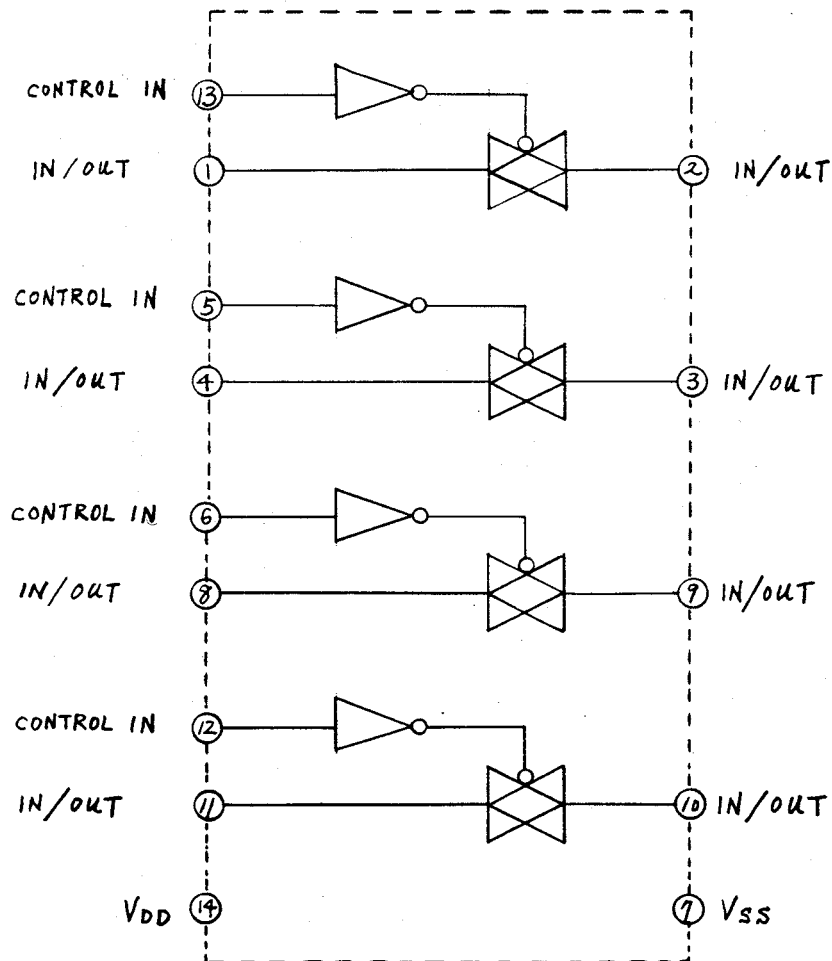

TC9142P

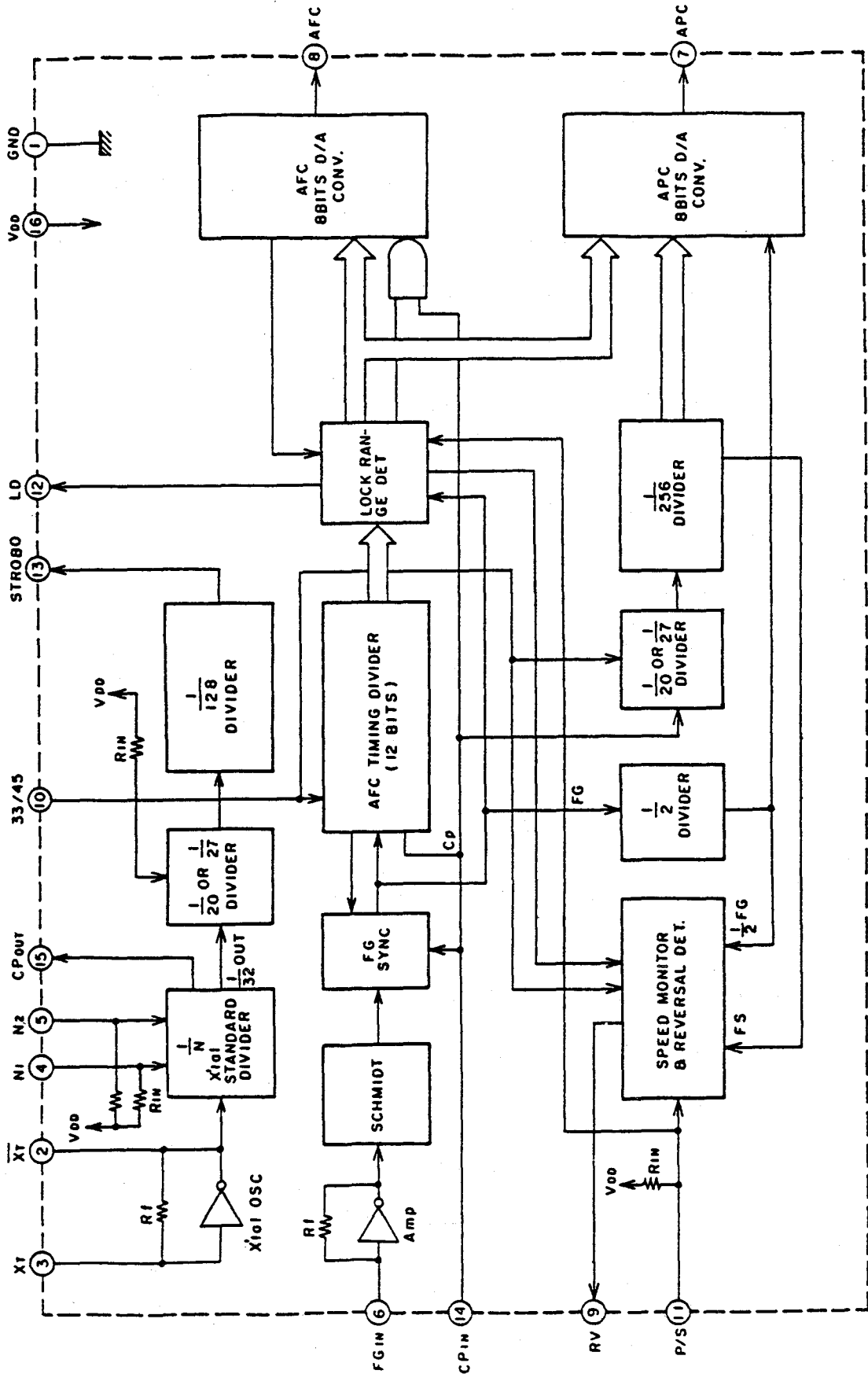

TC9142P

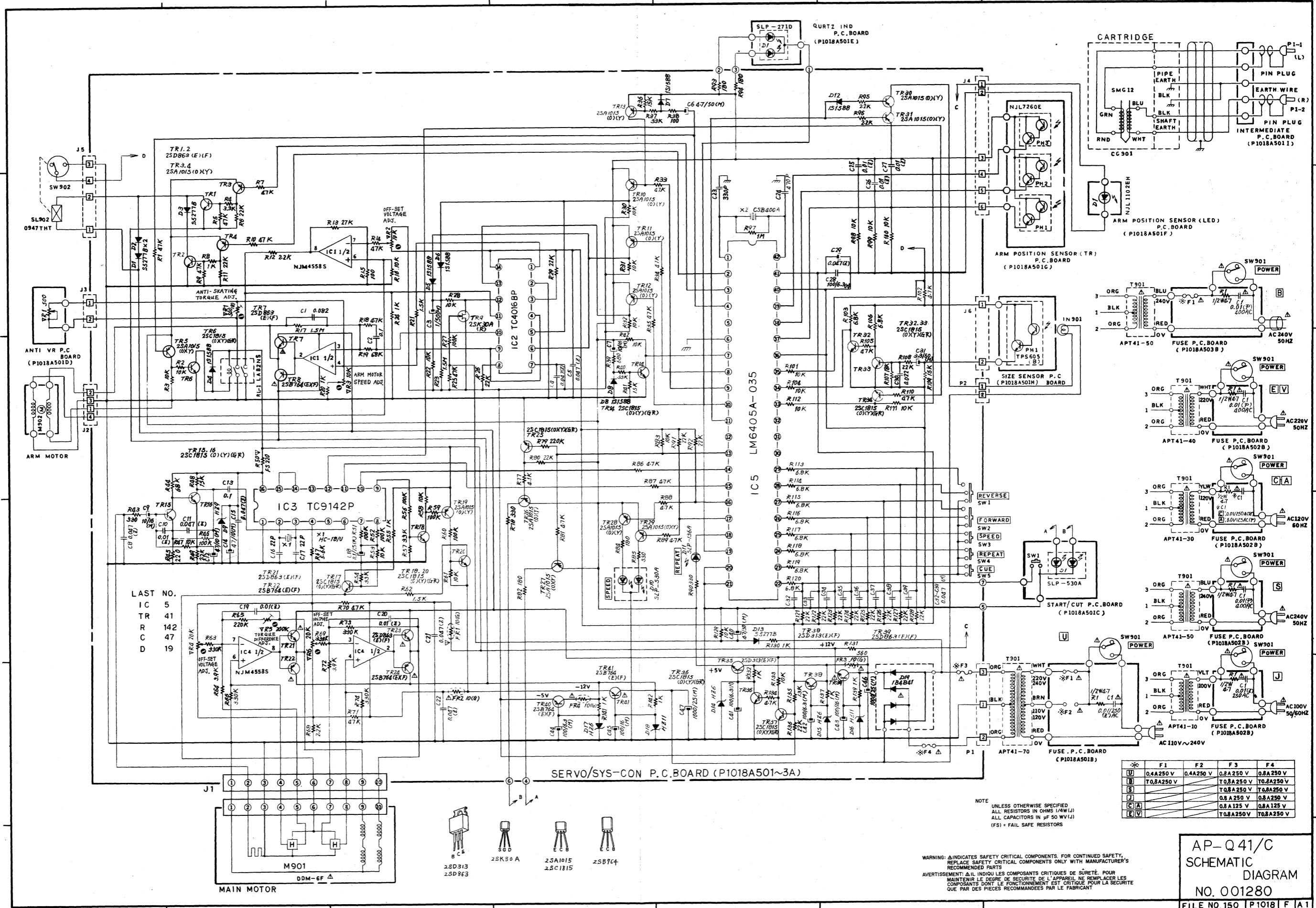

LAST NO.

IC	5
TR	41
C	142
R	47
D	19

	F1	F2	F3	F4
U	0.4A 250 V	0.4A 250 V	0.8A 250 V	0.8A 250 V
B	T0.8A 250 V		T0.8A 250 V	T0.8A 250 V
S			T0.8A 250 V	T0.8A 250 V
C	0.8 A 250 V		0.8 A 250 V	0.8 A 250 V
CA	0.8 A 125 V		0.8 A 125 V	
EV	T0.8A 250 V		T0.8A 250 V	

NOTE
 UNLESS OTHERWISE SPECIFIED
 ALL RESISTORS IN OHMS (1/W/L)
 ALL CAPACITORS IN µF 50 WV(L)
 (FS) = FAIL SAFE RESISTORS

WARNING: Δ INDICATES SAFETY CRITICAL COMPONENTS. FOR CONTINUED SAFETY, REPLACE SAFETY CRITICAL COMPONENTS ONLY WITH MANUFACTURER'S RECOMMENDED PARTS.
 AVERTISSEMENT: Δ IL INDIQUE LES COMPOSANTS CRITIQUES DE SÛRETÉ. POUR MAINTENIR LE DEGRÉ DE SÛRETÉ DE L'APPAREIL, NE REMPLACER LES COMPOSANTS DONT LE FONCTIONNEMENT EST CRITIQUE POUR LA SÛRETÉ QUE PAR DES PIÈCES RECOMMANDÉES PAR LE FABRICANT.

AP-Q41/C
 SCHEMATIC
 DIAGRAM
 NO. 001280
 FILE NO. 150 P1018 F 1A1

NJM4558S

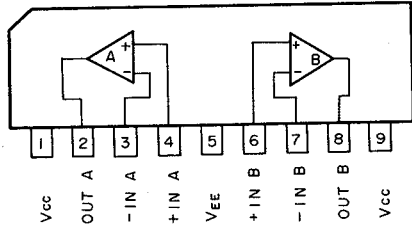

LM6405A-035

